

Specifications

Conditions of Sale

STANDARD: Seller's standard conditions of sale set forth in Price Sheet 150 apply.

SPECIAL TO THIS PRODUCT:

INCLUSIONS: Complete SMD® mountings and live parts include fuse-unit end fittings.

EXCLUSIONS: Complete mountings and live parts do not include fuse units.

Complete mountings and live parts do not include connectors. Various connectors are available as listed in the table on page 10. Specify quantity and catalog numbers of connectors desired.

SPECIFICATION NOTE: Gray station post insulators are standard for all mounting styles. When mountings are to be provided with special insulators, consult your nearest S&C Sales Office for availability.

Mountings can be supplied less insulators. Add suffix “-Z1” to the catalog number obtained from the tables on pages 2 and 3. Mountings (except Right-Angle Style and those rated 69 kV) of a given voltage rating can be provided with insulators of the next *higher* voltage rating—add suffix “-Z3” to the catalog number. In instances where insulators of the next higher voltage rating have different bolt-circle dimensions, adapters are required; consult your nearest S&C Sales Office for availability.

Mountings can be supplied less bases, but including insulators—add suffix “-Z4” to the catalog number.

Mountings and live parts (except SMD-50 Mountings and Live Parts and Upright Style SMD-2B Mountings and Live Parts rated 115 kV and 138 kV) can be supplied with tin-plated terminal pads. To specify, add suffix “-Z5” to the catalog number.

PACKING NOTE: Mountings rated 46 kV or less are shipped assembled with insulators. Higher rated mountings are shipped disassembled.

MAINTENANCE: Unlike relay-actuated protective devices such as circuit breakers and reclosers, power fuses have maintenance-free time-current characteristics and require only minimal physical maintenance—such as periodic checking of the condition of the fuse-unit bore and occasional refinishing of fuse tubes exposed to severe weathering. Checking the condition of the fuse-unit bore can easily be done in the field for SMD-1A, SMD-2B, and SMD-2C Fuse Units using the S&C Airflow Test Instrument. SMD-50 and SMD-3 Fuse Units are not suitable for airflow testing, but can be returned to S&C for disassembly and inspection, for a nominal charge. Refer to the tables entitled, “Maintenance Supplies” and “Inspection Equipment and Services” on page 11.

How to Order a Complete Power Fuse

1. Obtain the catalog number of the desired mounting from the “Complete Mounting” column on pages 2 through 5. If only live parts are desired, obtain catalog number from the “Live Parts” column.
2. Obtain the catalog number of the applicable fuse unit from the tables on pages 6 through 9, taking care to match the type and voltage rating of the fuse unit to that of the mounting. **Note:** If spare fuse-unit end fittings are required, refer to the selection table on page 12.
3. Obtain the catalog number of connectors from the table on page 10. Order two connectors for each mounting or set of live parts.

How to Order Handling Tools

Obtain the catalog number(s) of recommended handling tool(s) from the table on page 11. Refer to Specification Bulletin 851-31.

★ S&C Type SMD Power Fuses are manufactured in accordance with a quality system certified to ISO 9001:2000, and they are Rural Utilities Service (RUS) accepted.

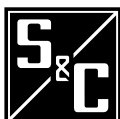

Mountings—Less Connectors^①

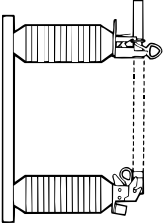
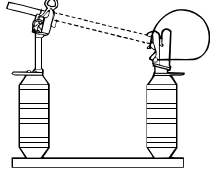
Style	For Fuse Unit	Rating					Catalog Number			Page Reference for Dimensional Information
		kV			Amperes, RMS, Symmetrical		Insulator T.R. No.	Complete Mounting (including Live Parts)	Live Parts (including End Fittings)	
		Nom.	Max	BIL	Max	Interrupting ^②				
Vertical 180° Opening ^③ 	SMD-50	34.5	38	200	100E	6 700	210	86534R3	3500R2	18
		46	48.3	250	100E	5 000	214	86535R3		
		69	72.5	350	100E	3 350	216	86536R3		
	SMD-1A	34.5	38	200	200E	17 500	210	186704R1	3700R3	19
		46	48.3	250	200E	13 100	214	186705R1		
		69	72.5	350	200E	8 750	216	186706R1		
SMD-2C	34.5	38	200	300E	33 500	210	186924R1	3600R1	19	
	46	48.3	250	300E	31 500	214	186925R1			
SMD-2B	69	72.5	350	300E	17 500	216	186926R1	3600R1	19	
	115	121	550	250E	10 500	286	186518	3980	20	
	138	145	650	250E	8 750	288	186519			
SMD-3	138	145	750	250E	8 750	291	186619			
	69	72.5	350	300E	25 000	216	192086	3610	19	
Vertical 45° Opening	SMD-2B	115	121	550	250E	10 500	286	186428R3	3900R3	20
		138	145	650	250E	8 750	288	186829R3		
		138	145	750	250E	8 750	291	186429R3		
Upright 	SMD-1A	34.5	38	200	200E	17 500	210	186724R1	3974■	21
		46	48.3	250	200E	13 100	214	186725R1		
		69	72.5	350	200E	8 750	216	186726R1		
	SMD-2C	34.5	38	200	300E	33 500	210	186994R1	3994★	21
		46	48.3	250	300E	31 500	214	186995R1		
	SMD-2B	69	72.5	350	300E	17 500	216	186996R1	3996★	21
		115	121	550	250E	10 500	286	186498R3	3948R3▲	22
		138	145	650	250E	8 750	288	186899R3		
SMD-3	138	145	750	250E	8 750	291	186499R3	3949R3▲		
	69	72.5	350	300E	25 000	216	192096	3656◆	21	

① For available connectors, refer to page 10.

② Symmetrical ratings assigned are based on available short-circuit current at locations where the X/R ratio is 15. The interrupting ratings expressed in amperes, RMS, asymmetrical are 1.6 times the symmetrical ratings listed. Higher symmetrical ratings have been determined for these fuses applied at lower system voltages and in locations where X/R = 10 and X/R = 5. These higher ratings as well as asymmetrical ratings are given in S&C Descriptive Bulletin 212-30.

③ Vertical 180° Opening Style Mountings (except SMD-50) are available with a hook to accommodate the obsolete S&C SMD Fuse Hoist. To specify mountings so equipped, add suffix “-H” to the catalog number of the mounting selected.

■ Where the hinge-end portions of the live parts are to be mounted on transformer bushings, specify Catalog Number 3744R1, 3745R1, or 3746R1, rated 34.5, 46, and 69 kV respectively. For information on bushing mounting of fuses, see S&C Information Sheet 212-450.

★ Where the hinge-end portions of the live parts are to be mounted on transformer bushings, specify Catalog Number 3644R1, 3645R1, or 3646R1, rated 34.5, 46, and 69 kV respectively. **Note:** For such applications the interrupting duty must be limited to 16,700, 12,500, or 8,400 amperes three-phase symmetrical at 34.5 kV, 46 kV, and 69 kV, respectively. For more information on bushing mounting of fuses, see S&C Information Sheet 212-450.

▲ Not recommended for mounting on transformer bushings; however, when absolutely required, the main-contact-end portions of the live parts must be mounted on the transformer bushings and the interrupting duty must be limited to 5,000 or 4,200 amperes three-phase symmetrical at 115 kV and 138 kV, respectively. For more information on bushing mounting of fuses, see S&C Information Sheet 212-450.

◆ Not recommended for mounting on transformer bushings.

TABLE CONTINUED ►

Mountings—Less Connectors^①—Continued

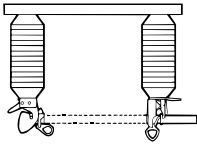
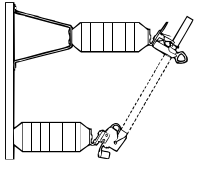
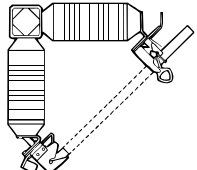
Style	For Fuse Unit	Rating					Catalog Number			Page Reference for Dimensional Information
		kV			Amperes, RMS, Symmetrical		Insulator T.R. No.	Complete Mounting (including Live Parts)	Live Parts (including End Fittings)	
		Nom.	Max	BIL	Max	Interrupting ^②				
Inverted 90° Opening ^③ 	SMD-1A	34.5	38	200	200E	17 500	210	186714R1	3720R1	23
		46	48.3	250	200E	13 100	214	186715R1		
		69	72.5	350	200E	8 750	216	186716R1		
	SMD-2C	34.5	38	200	300E	33 500	210	186944R1	3620R1	23
		46	48.3	250	300E	31 500	214	186945R1		
SMD-2B	69	72.5	350	300E	17 500	216	186946R1	3620R1	23	
	115	121	550	250E	10 500	286	186448R3	3920R3	24	
	138	145	650	250E	8 750	288	186849R3			
138	145	750	250E	8 750	291	186449R3				
SMD-3	69	72.5	350	300E	25 000	216	192326	3630	23	
	Inverted 135° Opening ^③	115	121	550	250E	10 500	286	186468	3925	25
		138	145	650	250E	8 750	288	186869		
		138	145	750	250E	8 750	291	186469		
Vertical—Offset 	SMD-50	34.5	38	200	100E	6 700	210	92044R3	3550R2	26
		46	48.3	250	100E	5 000	214	92045R3		
		69	72.5	350	100E	3 350	216	92046R3		
	SMD-1A	34.5	38	200	200E	17 500	210	192054	3790	27
46		48.3	250	200E	13 100	214	192055			
69		72.5	350	200E	8 750	216	192056			
SMD-2C	34.5	38	200	300E	33 500	210	192064	3780R2	27	
	46	48.3	250	300E	31 500	214	192065			
SMD-2B	69	72.5	350	300E	17 500	216	192066	3780R2	27	
Right-Angle 	SMD-50	34.5	38	200	100E	6 700	210	92024R3	3564R2	28
		46	48.3	250	100E	5 000	214	92025R3		
		69	72.5	350	100E	3 350	216	92026R3		
	SMD-1A	34.5	38	200	200E	17 500	210	192004R2	3754R2	29
		46	48.3	250	200E	13 100	214	192005R2		
		69	72.5	350	200E	8 750	216	192006R2		
	SMD-2C	34.5	38	200	300E	33 500	210	186864R2	3764R2	29
		46	48.3	250	300E	31 500	214	186865R2		
	SMD-2B	69	72.5	350	300E	17 500	216	186866R2	3766R2	29
	SMD-3	69	72.5	350	300E	25 000	216	192346	3686	29

① For available connectors, refer to page 10.

② Symmetrical ratings assigned are based on available short-circuit current at locations where the X/R ratio is 15. The interrupting ratings expressed in amperes, RMS, asymmetrical are 1.6 times the symmetrical ratings listed. Higher symmetrical ratings have been determined for these fuses applied at lower system voltages and in locations where X/R = 10 and X/R = 5. These higher ratings as well as asymmetrical ratings are given in S&C Descriptive Bulletin 212-30.

③ Inverted 135° Opening Style Mountings and Inverted 90° Opening Style Mountings are available with a hook to accommodate the obsolete S&C SMD Fuse Hoist. To specify mountings so equipped, add suffix "-H" to the catalog number of the mounting selected.

Mountings with Silicone-Housed Composite Polymer or Cypoxy™ Insulators—Less Connectors^①

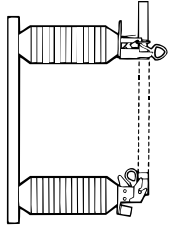
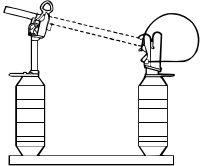
Style	For Fuse Unit	Rating					Complete Mounting (Including Live Parts)				Page Reference for Dimensional Information
		kV			Amperes, RMS, Symmetrical		Insulator T.R. No. ③	Catalog Number with Silicone-Housed Composite Polymer Insulators	Catalog Number with Cypoxy™ Insulators	Live Parts (including End Fittings)	
		Nom.	Max	BIL	Max	Interrupting ^②					
Vertical 180° Opening ^④ 	SMD-50	34.5 46 69	38 48.3 72.5	200 250 350	100E 100E 100E	6 700 5 000 3 350	210 214 216	86534R3-P 86535R3-P 86536R3-P	86534R3-E 86535R3-E —	3500R2	18
	SMD-1A	34.5 46 69	38 48.3 72.5	200 250 350	200E 200E 200E	17 500 13 100 8 750	210 214 216	186704R1-P 186705R1-P 186706R1-P	186704R1-E 186705R1-E —	3700R3	19
	SMD-2C	34.5 46	38 48.3	200 250	300E 300E	33 500 31 500	210 214	186924R1-P 186925R1-P	— 186925R1-E	3600R1	19
		69	72.5	350	300E	17 500	216	186926R1-P	—	3600R1	19
	SMD-2B	69	72.5	350	300E	17 500	216	186926R1-P	—	3600R1	19
		115 138 138	121 145 145	550 650 750	250E 250E 250E	10 500 8 750 8 750	286 288 291	186518-P 186519-P 186619-P	— — —	3980	20
SMD-3		69	72.5	350	300E	25 000	216	192086-P	—	3610	19
Vertical 45° Opening	SMD-2B	115 138 138	121 145 145	550 650 750	250E 250E 250E	10 500 8 750 8 750	286 288 291	186428R3-P 186829R3-P 186429R3-P	— — —	3900R3	20
Upright 	SMD-1A	34.5 46 69	38 48.3 72.5	200 250 350	200E 200E 200E	17 500 13 100 8 750	210 214 216	186724R1-P 186725R1-P 186726R1-P	186724R1-E 186725R1-E —	3974■ 3975■ 3976■	21
		SMD-2C	34.5 46	38 48.3	200 250	300E 300E	33 500 31 500	210 214	186994R1-P 186995R1-P	— 186995R1-E	3994★ 3995★
	SMD-2B		69	72.5	350	300E	17 500	216	186996R1-P	—	3996★
		115 138 138	121 145 145	550 650 750	250E 250E 250E	10 500 8 750 8 750	286 288 291	186498R3-P 186899R3-P 186499R3-P	— — —	3948R3▲ 3949R3▲ 3949R3▲	22
		SMD-3	69	72.5	350	300E	25 000	216	192096-P	—	3656◆

① For available connectors, refer to page 10.

② Symmetrical ratings assigned are based on available short-circuit current at locations where the X/R ratio is 15. The interrupting ratings expressed in amperes, RMS, asymmetrical are 1.6 times the symmetrical ratings listed. Higher symmetrical ratings have been determined for these fuses applied at lower system voltages and in locations where X/R = 10 and X/R = 5. These higher ratings as well as asymmetrical ratings are given in S&C Descriptive Bulletin 212-30.

③ T.R. No. shown is from corresponding mounting having porcelain station post insulators.

④ Vertical 180° Opening Style Mountings (except SMD-50) are available with a hook to accommodate the obsolete S&C SMD Fuse Hoist. To specify mountings so equipped, add suffix “-H” to the catalog number of the mounting selected.

■ Where the hinge-end portions of the live parts are to be mounted on transformer bushings, specify Catalog Number 3744R1, 3745R1, or 3746R1, rated 34.5, 46, and 69 kV respectively. For information on bushing mounting of fuses, see S&C Information Sheet 212-450.

★ Where the hinge-end portions of the live parts are to be mounted on transformer bushings, specify Catalog Number 3644R1, 3645R1, or 3646R1, rated 34.5, 46, and 69 kV respectively. **Note:** For such applications the interrupting duty must be limited to 16,700, 12,500, or 8,400 amperes three-phase symmetrical at 34.5 kV, 46 kV, and 69 kV, respectively. For more information on bushing mounting of fuses, see S&C Information Sheet 212-450.

▲ Not recommended for mounting on transformer bushings; however, when absolutely required, the main-contact-end portions of the live parts must be mounted on the transformer bushings and the interrupting duty must be limited to 5,000 or 4,200 amperes three-phase symmetrical at 115 kV and 138 kV, respectively. For more information on bushing mounting of fuses, see S&C Information Sheet 212-450.

◆ Not recommended for mounting on transformer bushings.

TABLE CONTINUED ►

Mountings with Silicone-Housed Composite Polymer or Cypoxy™ Insulators—Less Connectors①—Continued

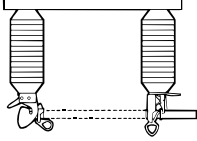
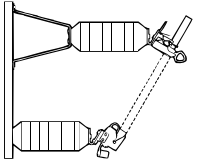
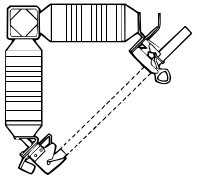
Style	For Fuse Unit	Rating					Complete Mounting (Including Live Parts)				Page Reference for Dimensional Information
		kV			Amperes, RMS, Symmetrical		Insulator T.R. No.③	Catalog Number with Silicone-Housed Composite Polymer Insulators	Catalog Number with Cypoxy™ Insulators	Live Parts (including End Fittings)	
		Nom.	Max	BIL	Max	Interrupting②					
Inverted 90° Opening④ 	SMD-1A	34.5 46 69	38 48.3 72.5	200 250 350	200E 200E 200E	17 500 13 100 8 750	210 214 216	186714R1-P 186715R1-P 186716R1-P	186714R1-E 186715R1-E —	3720R1	23
	SMD-2C	34.5 46	38 48.3	200 250	300E 300E	33 500 31 500	210 214	186944R1-P 186945R1-P	— 186945R1-E	3620R1	23
	SMD-2B	69	72.5	350	300E	17 500	216	186946R1-P	—	3620R1	23
		115 138 138	121 145 145	550 650 750	250E 250E 250E	10 500 8 750 8 750	286 288 291	186448R3-P 186849R3-P 186449R3-P	— — —	3920R3	24
	SMD-3	69	72.5	350	300E	25 000	216	192326-P	—	3630	23
Inverted 135° Opening	SMD-2B	115 138 138	121 145 145	550 650 750	250E 250E 250E	10 500 8 750 8 750	286 288 291	186468-P 186869-P 186469-P	— — —	3925	25
Vertical-Offset 	SMD-50	34.5 46 69	38 48.3 72.5	200 250 350	100E 100E 100E	6 700 5 000 3 350	210 214 216	92044R3-P 92045R3-P 92046R3-P	92044R3-E 92045R3-E —	3550R2	26
	SMD-1A	34.5 46 69	38 48.3 72.5	200 250 350	200E 200E 200E	17 500 13 100 8 750	210 214 216	192054-P 192055-P 192056-P	192054-E 192055-E —	3790	27
	SMD-2C	34.5 46	38 48.3	200 250	300E 300E	33 500 31 500	210 214	192064-P 192065-P	— 192065-E	3780R2	27
	SMD-2B	69	72.5	350	300E	17 500	216	192066-P	—	3780R2	27
Right-Angle 	SMD-50	34.5 46 69	38 48.3 72.5	200 250 350	100E 100E 100E	6 700 5 000 3 350	210 214 216	92024R3-P 92025R3-P 92026R3-P	92024R3-E 92025R3-E —	3564R2 3565R2 3566R2	28
	SMD-1A	34.5 46 69	38 48.3 72.5	200 250 350	200E 200E 200E	17 500 13 100 8 750	210 214 216	192004R2-P 192005R2-P 192006R2-P	192004R2-E 192005R2-E —	3754R2 3755R2 3756R2	29
	SMD-2C	34.5 46	38 48.3	200 250	300E 300E	33 500 31 500	210 214	186864R2-P 186865R2-P	— 186865R2-E	3764R2 3765R2	29
	SMD-2B	69	72.5	350	300E	17 500	216	186866R2-P	—	3766R2	29
	SMD-3	69	72.5	350	300E	25 000	216	192346-P	—	3686	29

① For available connectors, refer to page 10.

② Symmetrical ratings assigned are based on available short-circuit current at locations where the X/R ratio is 15. The interrupting ratings expressed in amperes, RMS, asymmetrical are 1.6 times the symmetrical ratings listed. Higher symmetrical ratings have been determined for these fuses applied at lower system voltages and in locations where X/R = 10 and X/R = 5. These higher ratings as well as asymmetrical ratings are given in S&C Descriptive Bulletin 212-30.

③ T.R. No. shown is from corresponding mounting having porcelain station post insulators.

④ Inverted 135° Opening Style Mountings (except SMD-50) and Inverted 90° Opening Style Mountings are available with a hook to accommodate the obsolete S&C SMD Fuse Hoist. To specify mountings so equipped, add suffix “-H” to the catalog number of the mounting selected.

SMD-1A Fuse Units

Rating, Amperes ↓	34.5 kV Nominal			46 kV Nominal			69 kV Nominal		
	Catalog Number			Catalog Number			Catalog Number		
Speed →	S&C Std. TCC 115-1			S&C Std. TCC 115-1			S&C Std. TCC 115-1		
1	444001R1			445001R1			446001R1		
Speed →	S&C Std. TCC 153-1	S&C Slow TCC 119-1	S&C Very Sl. TCC 176-1	S&C Std. TCC 153-1	S&C Slow TCC 119-1	S&C Very Sl. TCC 176-1	S&C Std. TCC 153-1	S&C Slow TCC 119-1	S&C Very Sl. TCC 176-1
3E	444003R2			445003R2			446003R2		
5E	444005R1			445005R1			446005R1		
7E	444007R1			445007R1			446007R1		
10E	444010R1			445010R1			446010R1		
13E	444013R1			445013R1			446013R1		
15E	444015R1	454015R1		445015R1	455015R1		446015R1	456015R1	
20E	444020R1	454020R1		445020R1	455020R1		446020R1	456020R1	
25E	444025R1	454025R1		445025R1	455025R1		446025R1	456025R1	
30E	444030R1	454030R1		445030R1	455030R1		446030R1	456030R1	
40E	444040R1	454040R1		445040R1	455040R1		446040R1	456040R1	
50E	444050R1	454050R1	564050	445050R1	455050R1	565050	446050R1	456050R1	566050
65E	444065R1	454065R1	564065	445065R1	455065R1	565065	446065R1	456065R1	566065
80E	444080R1	454080R1	564080	445080R1	455080R1	565080	446080R1	456080R1	566080
100E	444100R1	454100R1	564100	445100R1	455100R1	565100	446100R1	456100R1	566100
125E	444125R1	454125R1	564125	445125R1	455125R1	565125	446125R1	456125R1	566125
150E	444150R1	454150R1	564150	445150R1	455150R1	565150	446150R1	456150R1	566150
175E	444175R1	454175R1	564175	445175R1	455175R1	565175	446175R1	456175R1	566175
200E	444200R1	454200R1	564200	445200R1	455200R1	565200	446200R1	456200R1	566200

SMD-1A Fuse Units

Rating, Amperes ↓	115/138 kV Nominal	
	Catalog Number	
Speed →	S&C Std. TCC 153-1	S&C Slow TCC 119-1
20E	529020R2	539020R2
25E	529025R2	539025R2
30E	529030R2	539030R2
40E	529040R2	539040R2
50E	529050R2	539050R2
65E	529065R2	539065R2
80E	529080R2	539080R2
100E	529100R2	539100R2

SMD-2B Fuse Units

Rating, Amperes ↓	69 kV Nominal			115 kV Nominal			138 kV Nominal	
	Catalog Number			Catalog Number			Catalog Number	
Speed →	S&C Std. TCC 115-1			S&C Std. TCC 115-1			S&C Std. TCC 115-1	
1	466001R4			468001R4			469001R5	
Speed →	S&C Std. TCC 153-1	S&C Slow TCC 119-1	S&C Very Sl. TCC 176-1	S&C Std. TCC 153-1	S&C Slow TCC 119-1	S&C Very Sl. TCC 176-1	S&C Std. TCC 153-1	S&C Slow TCC 119-1
3E	466003R4			468003R4			469003R5	
5E	466005R4			468005R4			469005R5	
7E	466007R4			468007R4			469007R5	
10E	466010R4			468010R4			469010R5	
13E	466013R4			468013R4			469013R5	
15E	466015R4	486015R4		468015R4	488015R4		469015R5	489015R5
20E	466020R4	486020R4		468020R4	488020R4		469020R5	489020R5
25E	466025R4	486025R4		468025R4	488025R4		469025R5	489025R5
30E	466030R4	486030R4		468030R4	488030R4		469030R5	489030R5
40E	466040R4	486040R4		468040R4	488040R4		469040R5	489040R5
50E	466050R4	486050R4	576050R4	468050R4	488050R4	578050R4	469050R5	489050R5
65E	466065R4	486065R4	576065R4	468065R4	488065R4	578065R4	469065R5	489065R5
80E	466080R4	486080R4	576080R4	468080R4	488080R4	578080R4	469080R5	489080R5
100E	466100R4	486100R4	576100R4	468100R4	488100R4	578100R4	469100R5	489100R5
125E	466125R4	486125R4	576125R4	468125R4	488125R4	578125R4	469125R5	489125R5
150E	466150R4	486150R4	576150R4	468150R4	488150R4	578150R4	469150R5	489150R5
175E	466175R4	486175R4	576175R4	468175R4	488175R4	578175R4	469175R5	489175R5
200E	466200R4	486200R4	576200R4	468200R4	488200R4	578200R4	469200R5	489200R5
250E	466250R4	486250R4	576250R4	468250R4	488250R4	578250R4	469250R5	489250R5
300E	466300R4	486300R4						

SMD-2C Fuse Units

Rating, Amperes ↓	34.5 kV Nominal			46 kV Nominal		
	Catalog Number			Catalog Number		
Speed →	S&C Std. TCC 115-1			S&C Std. TCC 115-1		
1	464001R3			465001R3		
Speed →	S&C Std. TCC 153-1	S&C Slow TCC 119-1	S&C Very Sl. TCC 176-1	S&C Std. TCC 153-1	S&C Slow TCC 119-1	S&C Very Sl. TCC 176-1
3E	464003R3			465003R3		
5E	464005R3			465005R3		
7E	464007R3			465007R3		
10E	464010R3			465010R3		
13E	464013R3			465013R3		
15E	464015R3	484015R3		465015R3	485015R3	
20E	464020R3	484020R3		465020R3	485020R3	
25E	464025R3	484025R3		465025R3	485025R3	
30E	464030R3	484030R3		465030R3	485030R3	
40E	464040R3	484040R3		465040R3	485040R3	
50E	464050R3	484050R3	574050R3	465050R3	485050R3	575050R3
65E	464065R3	484065R3	574065R3	465065R3	485065R3	575065R3
80E	464080R3	484080R3	574080R3	465080R3	485080R3	575080R3
100E	464100R3	484100R3	574100R3	465100R3	485100R3	575100R3
125E	464125R3	484125R3	574125R3	465125R3	485125R3	575125R3
150E	464150R3	484150R3	574150R3	465150R3	485150R3	575150R3
175E	464175R3	484175R3	574175R3	465175R3	485175R3	575175R3
200E	464200R3	484200R3	574200R3	465200R3	485200R3	575200R3
250E	464250R3	484250R3	574250R3	465250R3	485250R3	575250R3
300E	464300R3	484300R3		465300R3	485300R3	

SMD-3 Fuse Units

Rating, Amperes ↓	69 kV Nominal		
	Catalog Number		
Speed →	S&C Std. TCC 115-1		
1	676001		
Speed →	S&C Std. TCC 153-1	S&C Slow TCC 119-1	S&C Very Slow TCC 176-1
3E	676003		
5E	676005		
7E	676007		
10E	676010		
13E	676013		
15E	676015	686015	
20E	676020	686020	
25E	676025	686025	
30E	676030	686030	
40E	676040	686040	
50E	676050	686050	696050
65E	676065	686065	696065
80E	676080	686080	696080
100E	676100	686100	696100
125E	676125	686125	696125
150E	676150	686150	696150
175E	676175	686175	696175
200E	676200	686200	696200
250E	676250	686250	696250
300E	676300	686300	

SMD-50 Fuse Units

Rating, Amperes ↓	34.5 kV Nominal		46 kV Nominal		69 kV Nominal	
	Catalog Number		Catalog Number		Catalog Number	
Speed →	S&C Std. TCC 153-1	S&C Slow TCC 119-1	S&C Std. TCC 153-1	S&C Slow TCC 119-1	S&C Std. TCC 153-1	S&C Slow TCC 119-1
5E	474005		475005		476005	
7E	474007		475007		476007	
10E	474010		475010		476010	
13E	474013		475013		476013	
15E	474015	494015	475015	495015	476015	496015
20E	474020	494020	475020	495020	476020	496020
25E	474025	494025	475025	495025	476025	496025
30E	474030	494030	475030	495030	476030	496030
40E	474040	494040	475040	495040	476040	496040
50E	474050	494050	475050	495050	476050	496050
65E	474065	494065	475065	495065	476065	496065
80E	474080	494080	475080	495080	476080	496080
100E	474100	494100	475100	495100	476100	496100

Connectors

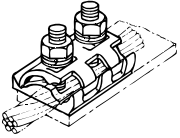
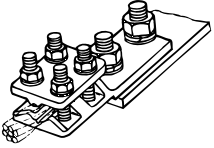
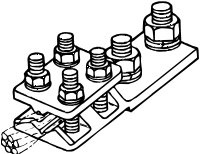
Illustration	Description	Accommodating Conductor	Catalog Number
	Aluminum Alloy Body, Tin Plated, 1/2-inch Galvanized Steel Hardware	No. 2 solid (33.6 mm ²) copper through 500 kc mil (335 mm ²) stranded copper or aluminum	4741R2
	Standard Bronze Pad Terminal, Tin Plated, Four-Bolt. Includes 1/2-inch galvanized steel hardware for attachment to terminal pads of fuses	No. 6 solid (13.3 mm ²) through 250 kc mil (168 mm ²) copper or aluminum	4564R1-B
		1/0 solid (53.5 mm ²) through 500 kc mil (335 mm ²) copper or aluminum	4565R1-B
		2/0 stranded (89 mm ²) through 800 kc mil (539 mm ²) copper or aluminum	4567R1-B
	Standard Aluminum Alloy Pad Terminal, Four-Bolt. Includes 1/2-inch galvanized steel hardware for attachment to terminal pads of fuses	No. 4 stranded (27.3 mm ²) through 1/0 stranded (70.5 mm ²) copper or aluminum	5326-B
		1/0 stranded (70.5 mm ²) through 250 kc mil (168 mm ²) copper or aluminum	5327-B
		250 kc mil (168 mm ²) through 400 kc mil (269 mm ²) copper or aluminum	5328-B

Maintenance Supplies

Item	For Fuse Unit	Catalog Number
Fuse-Unit Recoating Kit—one-half pint Tile Red Epoxy Polyester Gloss Enamel 3-R-1 and one-half pint Catalyst 13-C-0 (sufficient for two coats for four fuse units). ^① Requires thinner listed below	All	9900-026
Thinner for above—one pint	All	FA-104643

① Shelf life is one year from date of manufacture.

Inspection Equipment and Services

Item	For Fuse Unit	Catalog Number
S&C Airflow Test Instrument—includes all necessary meters and gauges for measuring the rate of airflow through applicable SMD Fuse Units, the necessary adapters and hoses for coupling the instrument to fuse units, complete operating instructions, and a laminated 8½" × 11" card providing recommended minimum airflow values. Source air pressure is not included	SMD-1A SMD-2B SMD-2C	4425
Disassembly and Inspection of Fuse Unit at S&C	SMD-50	◆
Disassembly Inspection of Fuse-Unit Bore at S&C	SMD-3	◆

◆ Consult your nearest S&C Sales Office.

Recommended Handling Tools

Item	For Fuse Unit	For Fuse Mounting		Catalog Number
		Style	Rating, kV	
Small Round Socket	SMD-1A	Vertical, 180° Opening Inverted, 90° Opening	69 kV and below	4408R4
Large Round Socket	SMD-1A	Vertical, 180° Opening	115, 138 kV	4407R4
	SMD-2C	Vertical, 180° Opening Inverted, 90° Opening	46 kV and below	
	SMD-2B SMD-3	Vertical, 180° Opening Inverted, 90° Opening	69 kV	
Station Prong	All	All	All	4402R2
Universal Pole				●

● Select to match height of installation. Refer to Specification Bulletin 851-31.

Parts

Item	For Fuse Unit	For Fuse Unit Rated kV, Nominal		Catalog Number
		From	To	
Spare Fuse-Unit End Fittings—Vertical, 180° Opening Style Mounting	SMD-1A	34.5	69	3004R1
	SMD-1A	115	138	3032R1
	SMD-2C	34.5	46	3032R1
	SMD-2B	—	69	3032R1
	SMD-2B	115	138	3081
	SMD-3	—	69	3033
	SMD-50	34.5	69	3091
Spare Fuse-Unit End Fittings—Vertical, 45° Opening Style Mounting	SMD-2B	115	138	3061R1
Spare Fuse-Unit End Fittings—Upright Style Mounting	SMD-1A	34.5	69	3024R1
	SMD-2C	34.5	46	3052R1
	SMD-2B	—	69	3052R1
	SMD-2B	115	138	3111
	SMD-3	—	69	3053
	SMD-50	34.5	69	3091
Spare Fuse-Unit End Fittings—Inverted, 90° Opening Style Mounting	SMD-1A	34.5	69	3014R1
	SMD-2C	34.5	46	3042R1
	SMD-2B	—	69	3042R1
	SMD-2B	115	138	3071
	SMD-3	—	69	3043
	SMD-50	34.5	69	3092
Spare Fuse-Unit End Fittings—Inverted, 135° Opening Style Mounting	SMD-2B	115	138	3075
Spare Fuse-Unit End Fittings—Vertical-Offset Style Mounting	SMD-1A	34.5	69	3004R1
	SMD-2C	34.5	46	3032R1
	SMD-2B	—	69	3032R1
	SMD-3	—	69	3033
	SMD-50	34.5	69	3091
Spare Fuse-Unit End Fittings—Right-Angle Style Mounting	SMD-1A	34.5	69	3004R1
	SMD-2C	34.5	46	3032R1
	SMD-2B	—	69	3032R1
	SMD-3	—	69	3033
	SMD-50	34.5	69	3091
Spare Fuse-Unit End Fittings—Pedestal Style Mounting	SMD-1A	34.5	69	3024R1
	SMD-2C	34.5	46	3052R1
	SMD-2B	—	69	3052R1
	SMD-2B	115	138	3111
	SMD-3	—	69	3053
Spare Fuse-Unit End Fittings—Cluster-Offset Style Mounting	SMD-50	34.5	69	3091
Spare Bumper—for Vertical, 180° Opening Style, Vertical-Offset Style, and Right-Angle Style Mountings	SMD-1A	34.5	115/138	SA-30731
	SMD-2C	34.5	46	
	SMD-2B	—	69	
	SMD-3	—	69	
Spare Bumper—for Vertical, 45° Opening Style	SMD-2B	115	138	SA-30731

Spare or Replacement Live Parts, Less End Fittings—Upper and Lower Live Parts Sold Separately

Mounting Style	For Fuse Unit	For Fuse Unit Rated kV, Nominal		Upper Contact Assembly	Lower Hinge Assembly
		From	To	Catalog Number	Catalog Number
Vertical—180° Opening	SMD-50	34.5	69	SA-34054	SA-34053
	SMD-1A	34.5	69	SA-38409	SA-38411
	SMD-2C	34.5	46	SA-38409	SA-38411
	SMD-2B	—	69	SA-38409	SA-38411
		115	138	SA-33641	SA-33642
SMD-3	—	69	SA-38409	SA-38411	
Vertical—45° Opening	SMD-2B	115	138	SA-33636-1	SA-33707
Upright	SMD-1A	—	34.5	SA-38015-1	SA-37010
		—	46	SA-38015-2	SA-37010
		—	69	SA-38015-3	SA-37010
	SMD-2C	—	34.5	SA-38015-1	SA-37010
		—	46	SA-38015-2	SA-37010
	SMD-2B	—	69	SA-38015-3	SA-37010
		115	138	SA-33636-2	SA-33776
	SMD-3	—	69	SA-38015-3	SA-38052
	Inverted—90° Opening	SMD-1A	34.5	69	SA-38409
SMD-2C		34.5	46	SA-38409	SA-38412
SMD-2B		—	69	SA-38409	SA-38412
		115	138	SA-33636-1	SA-33640
SMD-3		—	69	SA-38409	SA-38412
Vertical-Offset and Right Angle	SMD-50	34.5	69	SA-34054	SA-34053
	SMD-1A	34.5	69	SA-38409	SA-34555
	SMD-2C	34.5	46	SA-38409	SA-34555
	SMD-2B	—	69	SA-38409	SA-34555
	SMD-3	—	69	SA-38409	SA-34555

Spare or Replacement End Fittings—Upper and Lower End Fittings Sold Separately

Mounting Style	For Fuse Unit	For Fuse Unit Rated kV, Nominal		Upper End Fitting	Lower End Fitting
		From	To	Catalog Number	Catalog Number
Vertical—180° Opening, Vertical-Offset, and Right-Angle	SMD-50	34.5	69	SA-34056	SA-34055
	SMD-1A	34.5	69	SA-31208	SA-31209
		115	138	SA-38045●	S-77269●
	SMD-2C	34.5	46	SA-38045	S-77269
	SMD-2B	—	69	SA-38045	S-77269
		115	138	SA-30424R1●	SA-33643●
SMD-3	—	69	SA-36937	S-77571	
Vertical—45° Opening	SMD-2B	115	138	SA-30424R1	SA-33710
Upright and Pedestal	SMD-50	34.5	69	SA-34056■	SA-34055■
	SMD-1A	34.5	69	SA-31208	SA-31212
	SMD-2C	34.5	46	SA-38045	S-79757
	SMD-2B	—	69	SA-38045	S-79757
		115	138	SA-30424R1	SA-34002
SMD-3	—	69	SA-36937	S-79758	
Inverted—90° Opening	SMD-50	34.5	69	SA-34056	SA-34104
	SMD-1A	34.5	69	SA-31208	SA-31213
	SMD-2C	34.5	46	SA-38045	S-79759
	SMD-2B	—	69	SA-38045	S-79759
		115	138	SA-30424R1	SA-33401
SMD-3	—	69	SA-36937	S-79760	
Cluster-Offset	SMD-50	34.5	69	SA-34056	SA-34055

● Vertical 180° Opening style mounting only.

■ Upright style mounting only.

Conversion Kits—For Converting Southern States Power Fuses

Southern States Power Fuses, Type BPA, HPA, and BP							S&C Conversion Kit ^①				
Style	Type	Rating					For Fuse Unit	Catalog Number			
		kV			Amperes, RMS						
		Nom.	Max	BIL	Max	Interr. Asym.					
Vertical	BPA	34.5	38	200	100	10 000	SMD-50	FXA-1006-1			
					100 or 200	20 000	SMD-1A	FXA-1009-1			
		46	48.3	250	100	8 000	SMD-50	FXA-1006-2			
					100 or 200	16 000	SMD-1A	FXA-1009-2			
		69	72.5	350	100 or 200	12 500	SMD-1A	FXA-1009-3			
	HPA	34.5	38	200	100, 200, or 300	31 500	SMD-2C	FXA-1007-1			
					400	31 500	—	②			
		46	48.3	250	100, 200, or 300	25 000 or 40 000	SMD-2C	FXA-1007-2			
					400	40 000	—	②			
		69	72.5	350	100, 200, or 300	20 000	SMD-2B	FXA-1007-3			
					100, 200, or 300	31 500	SMD-3	FXA-1008			
					400	31 500	—	②			
		115	121	550	100 or 200	16 000	SMD-2B	FXA-1010-1			
					100 or 200	25 000	—	②			
					138	145	650	100 or 200	12 500	SMD-2B	FXA-1010-2
								100 or 200	20 000	—	②
	BP	34.5	38	200	100	8 000	SMD-50	FXA-1006-1			
					200	8 000	SMD-1A	FXA-1009-1			
		46	48.3	250	100	8 000	SMD-50	FXA-1006-2			
					200	12 500	SMD-1A	FXA-1009-2			
		69	72.5	350	100 or 200	12 500	SMD-1A	FXA-1009-1			

① Each conversion kit listed in this table utilizes the least-expensive S&C SMD® Fuse Unit matching or exceeding the maximum-current and interrupting ratings of the associated Southern States Power Fuse.

② There is no conversion kit available for this Southern States Power Fuse.

TABLE CONTINUED ►

Conversion Kits—For Converting Southern States Power Fuses—Continued

Southern States Power Fuses, Type BPA, HPA, and BP							S&C Conversion Kit ^①	
Style	Type	Rating					For Fuse Unit	Catalog Number
		kV			Amperes, RMS			
		Nom.	Max	BIL	Max	Interr. Asym.		
Underhung (Inverted)	BPA	34.5	38	200	100	10 000	SMD-1A	FXA-1013-1
					100 or 200	20 000	SMD-1A	FXA-1013-1
		46	48.3	250	100	8 000	SMD-1A	FXA-1013-2
					100 or 200	16 000	SMD-1A	FXA-1013-2
		69	72.5	350	100 or 200	12 500	SMD-1A	FXA-1013-3
		HPA	34.5	38	200	100, 200, or 300	31 500	SMD-2C
	400					31 500	—	②
	46		48.3	250	100, 200, or 300	25 000 or 40 000	SMD-2C	FXA-1011-2
					400	40 000	—	②
	69		72.5	350	100, 200, or 300	20 000	SMD-2B	FXA-1011-3
					100, 200, or 300	31 500	SMD-3	FXA-1012
					400	31 500	—	②
	115		121	550	100 or 200	16 000	SMD-2B	FXA-1014-1
					100 or 200	25 000	—	②
	138		145	650	100 or 200	12 500	SMD-2B	FXA-1014-2
		100 or 200			20 000	—	②	

① Each conversion kit listed in this table utilizes the least-expensive S&C SMD® Fuse Unit matching or exceeding the maximum-current and interrupting ratings of the associated Southern States Power Fuse.

② There is no conversion kit available for this Southern States Power Fuse.

TABLE CONTINUED ►

Conversion Kits—For Converting Southern States Power Fuses—Continued

Southern States Power Fuses, Type BPA, HPA, and BP							S&C Conversion Kit ^①		
Style	Type	Rating					For Fuse Unit	Catalog Number	
		kV			Amperes, RMS				
		Nom.	Max	BIL	Max	Interr. Asym.			
45° Underhung (Right-Angle Style)	BPA	34.5	38	200	100	10 000	SMD-50	FXA-1018-1	
					100 or 200	20 000	SMD-1A	FXA-1016-1	
		46	48.3	250	100	8 000	SMD-50	FXA-1018-2	
					100 or 200	16 000	SMD-1A	FXA-1016-2	
		69	72.5	350	100 or 200		12 500	SMD-1A	FXA-1016-3
					100, 200, or 300		31 500	SMD-2C	FXA-1017-1
	HPA	34.5	38	200	400	31 500	—	②	
					100, 200, or 300		25 000 or 40 000	SMD-2C	FXA-1017-2
		46	48.3	250	400	40 000	—	②	
					100, 200, or 300		20 000	SMD-2B	FXA-1017-3
		69	72.5	350	100, 200, or 300		31 500	SMD-3	FXA-1015
					400		31 500	—	②
					100 or 200		16 000	—	②
		115	121	550	100 or 200		25 000	—	②
					100 or 200		12 500	—	②
		138	145	650	100 or 200		20 000	—	②

① Each conversion kit listed in this table utilizes the least-expensive S&C SMD® Fuse Unit matching or exceeding the maximum-current and interrupting ratings of the associated Southern States Power Fuse.

② There is no conversion kit available for this Southern States Power Fuse.

Vertical, 180° Opening Style
SMD-50
34.5, 46, and 69 kV

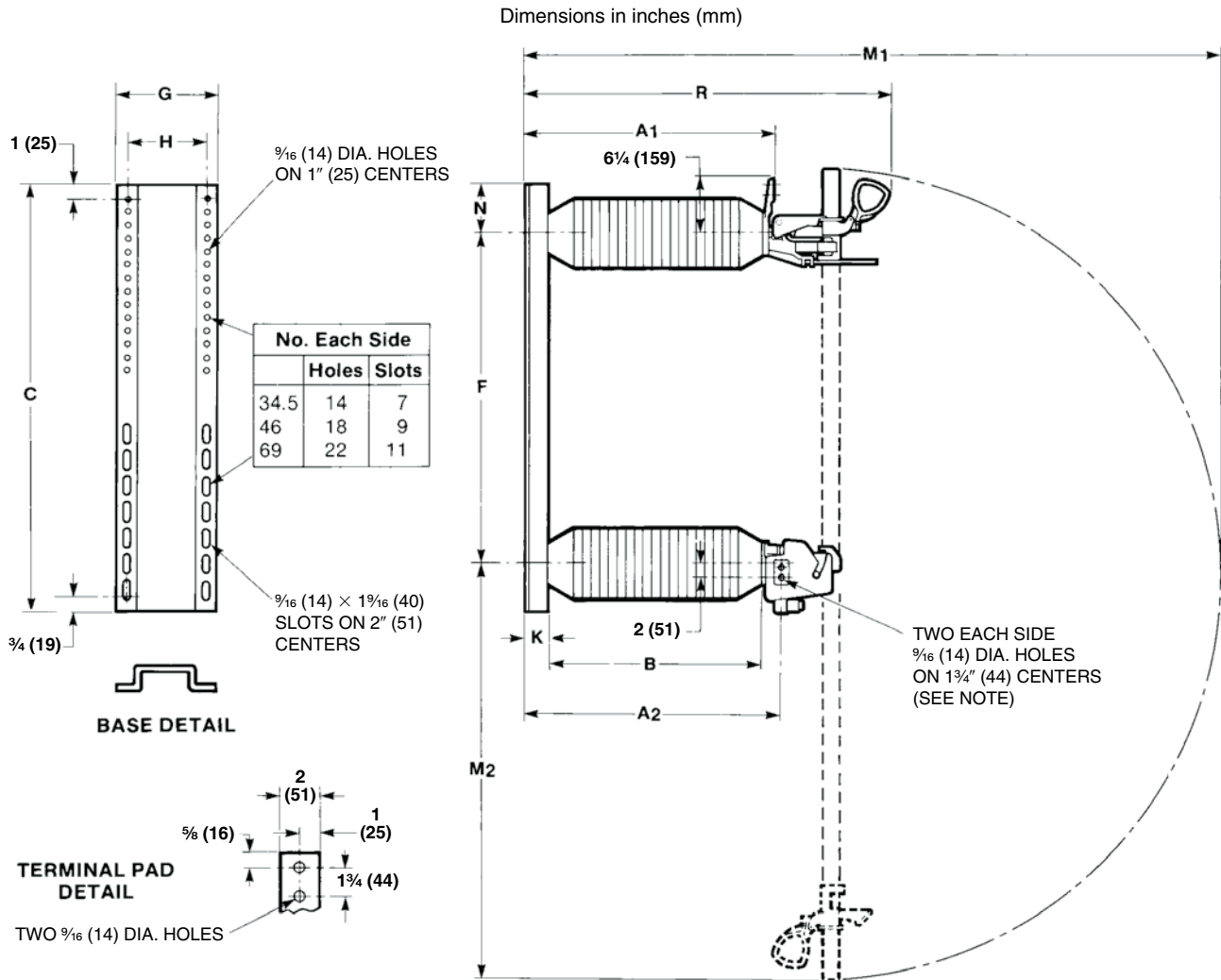

NOTE: Dimension between terminal pad surfaces on hinge is 6 1/4 inches (159 mm).

Rating				Catalog Number Complete Mounting (including Live Parts)	Dimensions in Inches (mm)										Net Wt., Lbs. (Kg.) ①		
kV		Amps, Max	BIL		A ₁	A ₂	B	C	F	G	H	K	M ₁	M ₂		N	R
Nom.	Max																
34.5	38	200	100E	86534R3, 86534R3-P, 86534R3-E	20 7/8 (530)	22 (559)	18 (457)	35 1/2 (902)	29 1/4 (743)	8 7/8 (225)	7 (178)	2 (51)	62 5/8 (1591)	38 1/8 (968)	3 1/8 (79)	31 3/4 (806)	120 (54)
46	48.3	250	100E	86535R3, 86535-P, 86535-E	25 1/8 (638)	26 1/4 (667)	22 (559)	43 (1092)	33 1/4 (845)	10 (254)	8 1/4 (210)	2 1/4 (57)	70 7/8 (1800)	42 1/8 (1070)	4 7/8 (124)	36 (914)	165 (75)
69	72.5	350	100E	86536R3, 86536R3-E	33 1/8 (841)	34 1/4 (870)	30 (762)	52 (1321)	41 1/4 (1048)	10 (254)	8 1/4 (210)	2 1/4 (57)	86 7/8 (2207)	50 1/8 (1273)	5 3/8 (137)	44 (1118)	240 (109)

① Weights shown apply to mountings furnished with porcelain insulators. Mountings furnished with polymer or Cyproxy insulators weigh less.

Vertical, 180° Opening Style
SMD-1A, SMD-2B, SMD-2C, and SMD-3
34.5, 46, and 69 kV

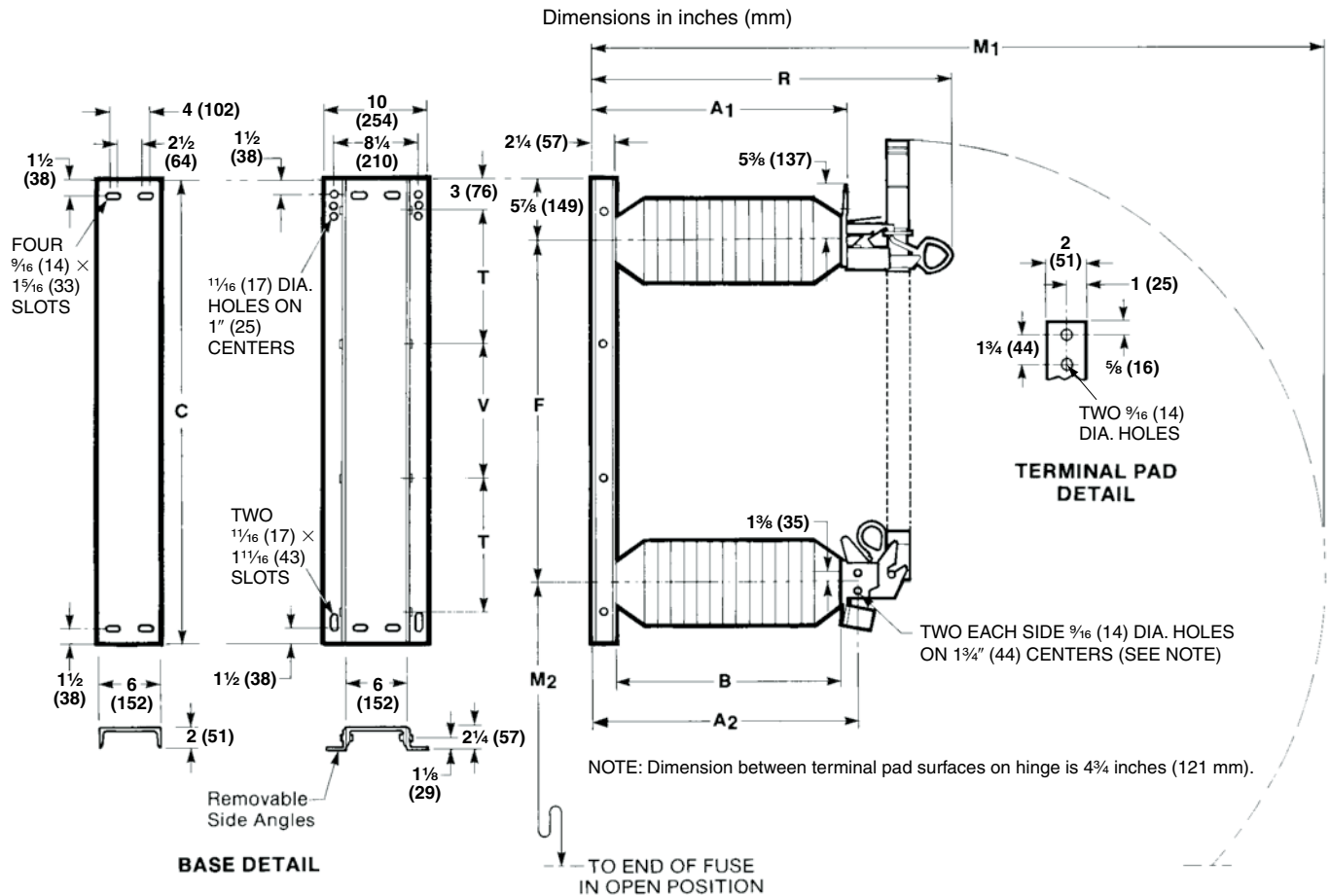

For Fuse Unit	Rating				Catalog Number Complete Mounting (including Live Parts)	Dimensions in Inches (mm)										Net Wt., Lbs. (Kg.) ①
	kV			Amps, Max		A1▲	A2▲	B	C	F	M1▲	M2	RA▲	T	V	
	Nom.	Max	BIL													
SMD-1A	34.5	38	200	200E	186704R1, 186704R1-P, 186704R1-E	20¾ (527)	21⅞ (556)	18 (457)	41 (1041)	29¼ (743)	61⅞ (1572)	36¼ (921)	31⅞ (791)	17½ (445)	— (—)	145 (66)
	46	48.3	250	200E	186705R1, 186705R1-P, 186705R1-E	24¾ (629)	25⅞ (657)	22 (559)	45 (1143)	33¼ (845)	70⅞ (1781)	40¼ (1022)	35⅞ (892)	13 (330)	13 (330)	200 (91)
	69	72.5	350	200E	186706R1, 186706R1-P	32¾ (832)	33⅞ (860)	30 (762)	53 (1346)	41¼ (1048)	86⅞ (2188)	48¼ (1226)	43⅞ (1095)	15 (381)	17 (432)	315 (143)
SMD-2C	34.5	38	200	300E	186924R1, 186924R1-P	20¾ (527)	21⅞ (556)	18 (457)	41 (1041)	29¼ (743)	63⅞ (1603)	37½ (953)	31⅞ (791)	17½ (445)	— (—)	145 (66)
	46	48.3	250	300E	186925R1, 186925R1-P, 186925R1-E	24¾ (629)	25⅞ (657)	22 (559)	45 (1143)	33¼ (845)	71⅞ (1813)	41½ (1054)	35⅞ (892)	13 (330)	13 (330)	200 (91)
SMD-2B	69	72.5	350	300E	186926R1, 186926R1-P	32¾ (832)	33⅞ (860)	30 (762)	53 (1346)	41¼ (1048)	87⅞ (2219)	49½ (1257)	43⅞ (1095)	15 (381)	17 (432)	315 (143)
SMD-3	69	72.5	350	300E	192086, 192086-P	32¾ (832)	33⅞ (860)	30 (762)	53 (1346)	41¼ (1048)	94¼ (2394)	56⅞ (1438)	43⅞ (1095)	15 (381)	17 (432)	315 (143)

① Weights shown apply to mountings furnished with porcelain insulators. Mountings furnished with polymer or Cypoxy insulators weigh less.

▲ These dimensions decrease ¼ inch (6 mm) when side angles are removed from base.

Vertical, 180° and 45° Opening Styles
SMD-2B
 115 and 138 kV

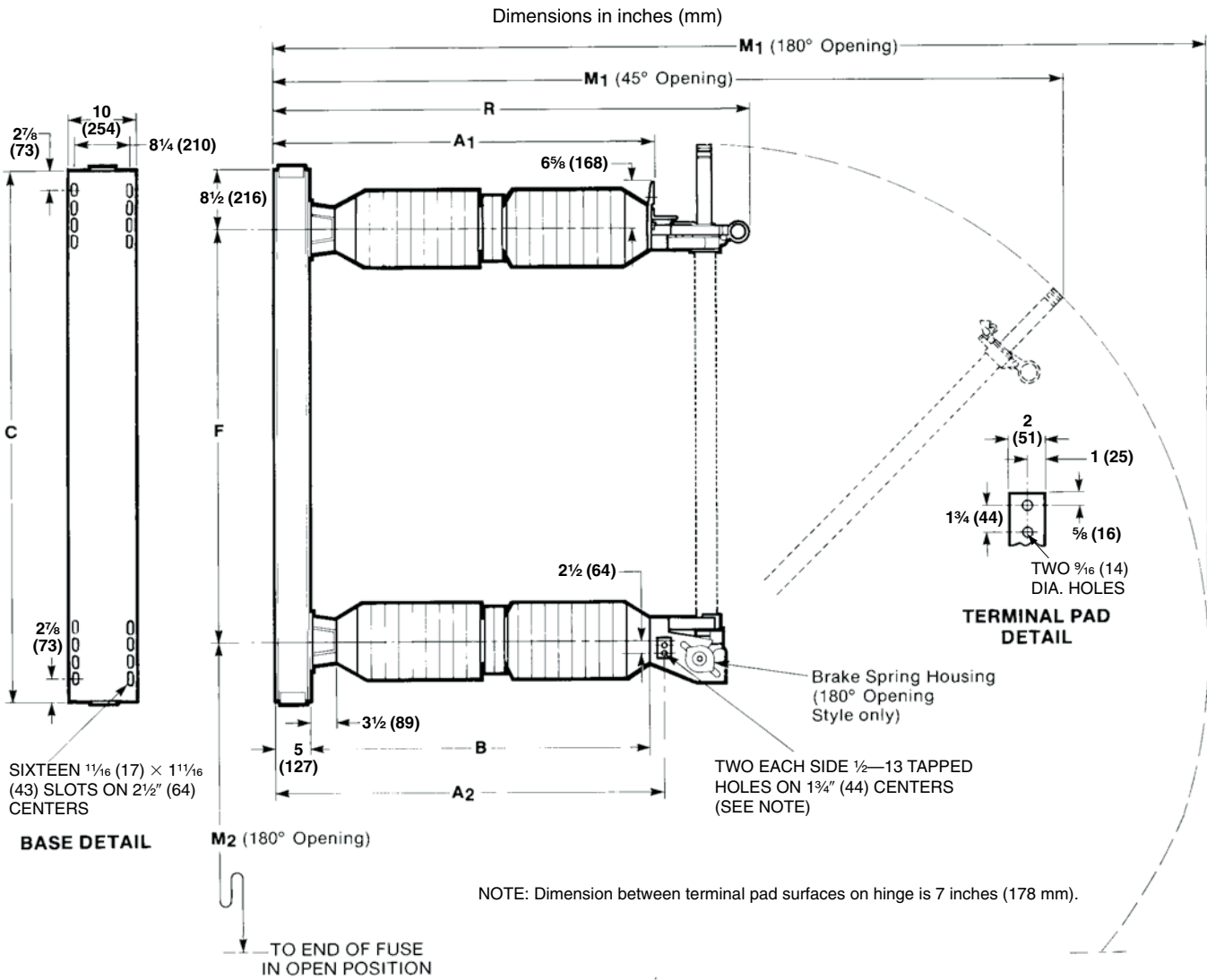

Rating				Catalog Number Complete Mounting (including Live Parts)	Dimensions in Inches (mm)							Net Wt., Lbs. (Kg.) ①	
kV			Amps, Max		A ₁	A ₂	B	C	F	M ₁	M ₂		R
Nom.	Max	BIL											
115	121	550	250E	186518, 186518-P	54 (1372)	55 (1397)	48 1/2 (1232)	76 3/4 (1949)	59 3/4 (1518)	135 7/8 (3451)	78 (1981)	68 3/8 (1737)	550 (249)
138	145	650	250E	186519, 186519-P	63 (1600)	64 (1626)	57 1/2 (1461)	84 3/4 (2153)	67 3/4 (1721)	152 7/8 (3883)	86 (2184)	77 3/8 (1965)	605 (274)
138	145	750	250E	186619, 186619-P	71 (1803)	72 (1829)	65 1/2 (1664)	84 3/4 (2153)	67 3/4 (1721)	160 7/8 (4086)	86 (2184)	85 3/8 (2169)	665 (302)
115	121	550	250E	186428R3, 186428R3-P	54 (1372)	55 (1397)	48 1/2 (1232)	76 3/4 (1949)	59 3/4 (1518)	121 (3073)	— (—)	68 3/8 (1737)	550 (249)
138	145	650	250E	186829R3, 186829R3-P	63 (1600)	64 (1626)	57 1/2 (1461)	84 3/4 (2153)	67 3/4 (1721)	136 1/8 (3458)	— (—)	77 3/8 (1965)	605 (274)
138	145	750	250E	186429R3, 186429R3-P	71 (1803)	72 (1829)	65 1/2 (1664)	84 3/4 (2153)	67 3/4 (1721)	144 1/8 (3661)	— (—)	85 3/8 (2169)	665 (302)

① Weights shown apply to mountings furnished with porcelain insulators. Mountings furnished with polymer or Cyproxy insulators weigh less.

Upright Style
SMD-1A, SMD-2B, SMD-2C, and SMD-3
34.5, 46, and 69 kV

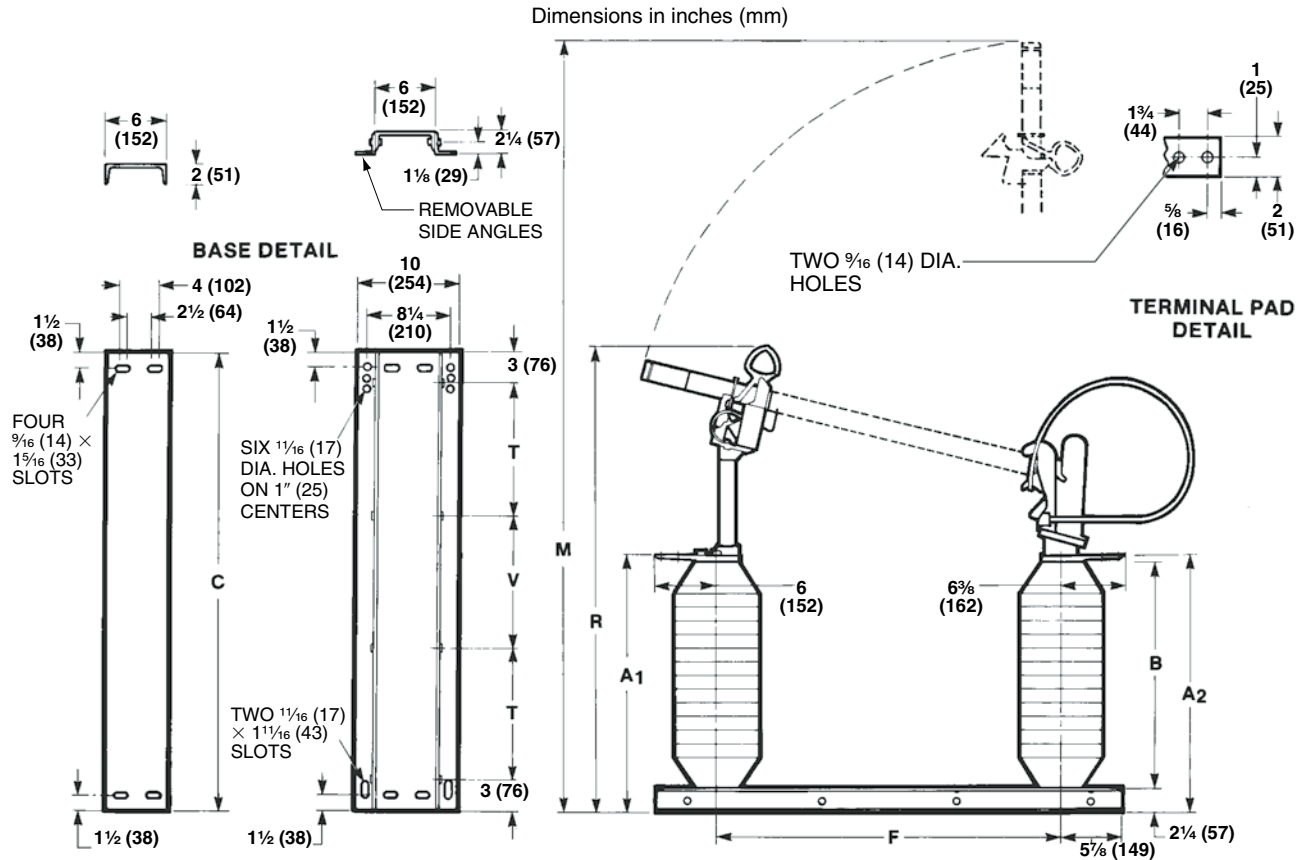

For Fuse Unit	Rating				Catalog Number Complete Mounting (including Live Parts)	Dimensions in Inches (mm)								Net Wt., Lbs. (Kg.) ①	
	kV			Amps, Max		A1●	A2●	B	C	F	M●	R●	T		V
	Nom.	Max	BIL												
SMD-1A	34.5	38	200	200E	186724R1, 186724R1-P, 186724R1-E	20 3/4 (527)	20 1/2 (521)	18 (457)	41 (1041)	29 1/4 (743)	64 1/2 (1632)	40 (1016)	17 1/2 (445)	— (—)	170 (77)
	46	48.3	250	200E	186725R1, 186725R1-P, 186725R1-E	24 3/4 (629)	24 1/2 (616)	22 (559)	45 (1143)	33 1/4 (845)	72 1/2 (1842)	45 (1143)	13 (330)	13 (330)	220 (100)
	69	72.5	350	200E	186726R1, 186726R1-P	32 3/4 (832)	32 1/2 (826)	30 (762)	53 (1346)	41 1/4 (1048)	88 1/2 (2248)	55 (1397)	15 (381)	17 (432)	335 (152)
SMD-2C	34.5	38	200	300E	186994R1, 186994R1-P	20 3/4 (527)	20 1/2 (521)	18 (457)	41 (1041)	29 1/4 (743)	65 3/4 (1670)	40 (1016)	17 1/2 (445)	— (—)	170 (77)
	46	48.3	250	300E	186995R1, 186995R1-P, 186995R1-E	24 3/4 (629)	24 1/2 (616)	22 (559)	45 (1143)	33 1/4 (845)	73 3/4 (1873)	45 (1143)	13 (330)	13 (330)	220 (100)
SMD-2B	69	72.5	350	300E	186996R1, 186996R1-P	32 3/4 (832)	32 1/2 (826)	30 (762)	53 (1346)	41 1/4 (1048)	89 3/4 (2280)	55 (1397)	15 (381)	17 (432)	335 (152)
SMD-3	69	72.5	350	300E	192096, 192096-P	32 3/4 (832)	32 3/4 (832)	30 (762)	53 (1346)	41 1/4 (1048)	96 3/4 (2457)	56 (1422)	15 (381)	17 (432)	335 (152)

① Weights shown apply to mountings furnished with porcelain insulators. Mountings furnished with polymer or Cytopoxy insulators weigh less.

● These dimensions decrease 1/4 inch (6 mm) when side angles are removed from base.

**Upright Style
SMD-2B
115 and 138 kV**

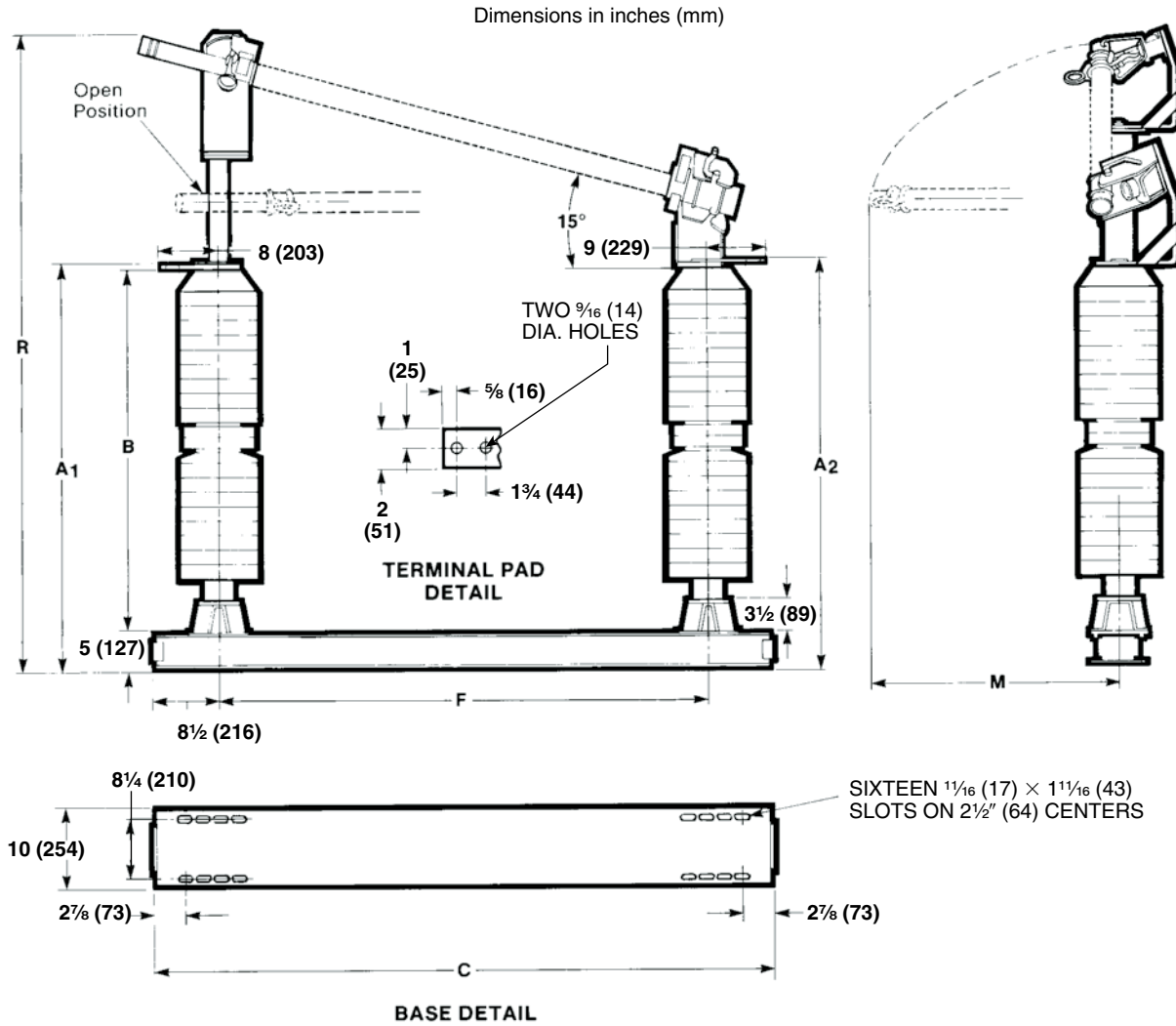

Rating				Catalog Number Complete Mounting (including Live Parts)	Dimensions in Inches (mm)							Net Wt., Lbs. (Kg.) ①
kV			Amps, Max		A ₁	A ₂	B	C	F	M	R	
Nom.	Max	BIL										
115	121	550	250E	186498R3, 186498R3-P	53 ⁷ / ₈ (1368)	54 ³ / ₈ (1381)	48 ¹ / ₂ (1232)	76 ³ / ₄ (1949)	59 ³ / ₄ (1518)	26 ¹ / ₈ (664)	81 ⁵ / ₈ (2073)	600 (272)
138	145	650	250E	186899R3, 186899R3-P	62 ⁷ / ₈ (1597)	63 ³ / ₈ (1610)	57 ¹ / ₂ (1461)	84 ³ / ₄ (2153)	67 ³ / ₄ (1721)	34 ¹ / ₈ (870)	92 ⁵ / ₈ (2353)	655 (297)
138	145	750	250E	186499R3, 186499R3-P	70 ⁷ / ₈ (1800)	71 ³ / ₈ (1813)	65 ¹ / ₂ (1664)	84 ³ / ₄ (2153)	67 ³ / ₄ (1721)	34 ¹ / ₈ (870)	100 ⁵ / ₈ (2556)	715 (324)

① Weights shown apply to mountings furnished with porcelain insulators. Mountings furnished with polymer or Cyproxy insulators weigh less.

Inverted 90° Opening Style
SMD-1A, SMD-2B, SMD-2C, and SMD-3
34.5, 46, and 69 kV

Dimensions in inches (mm)

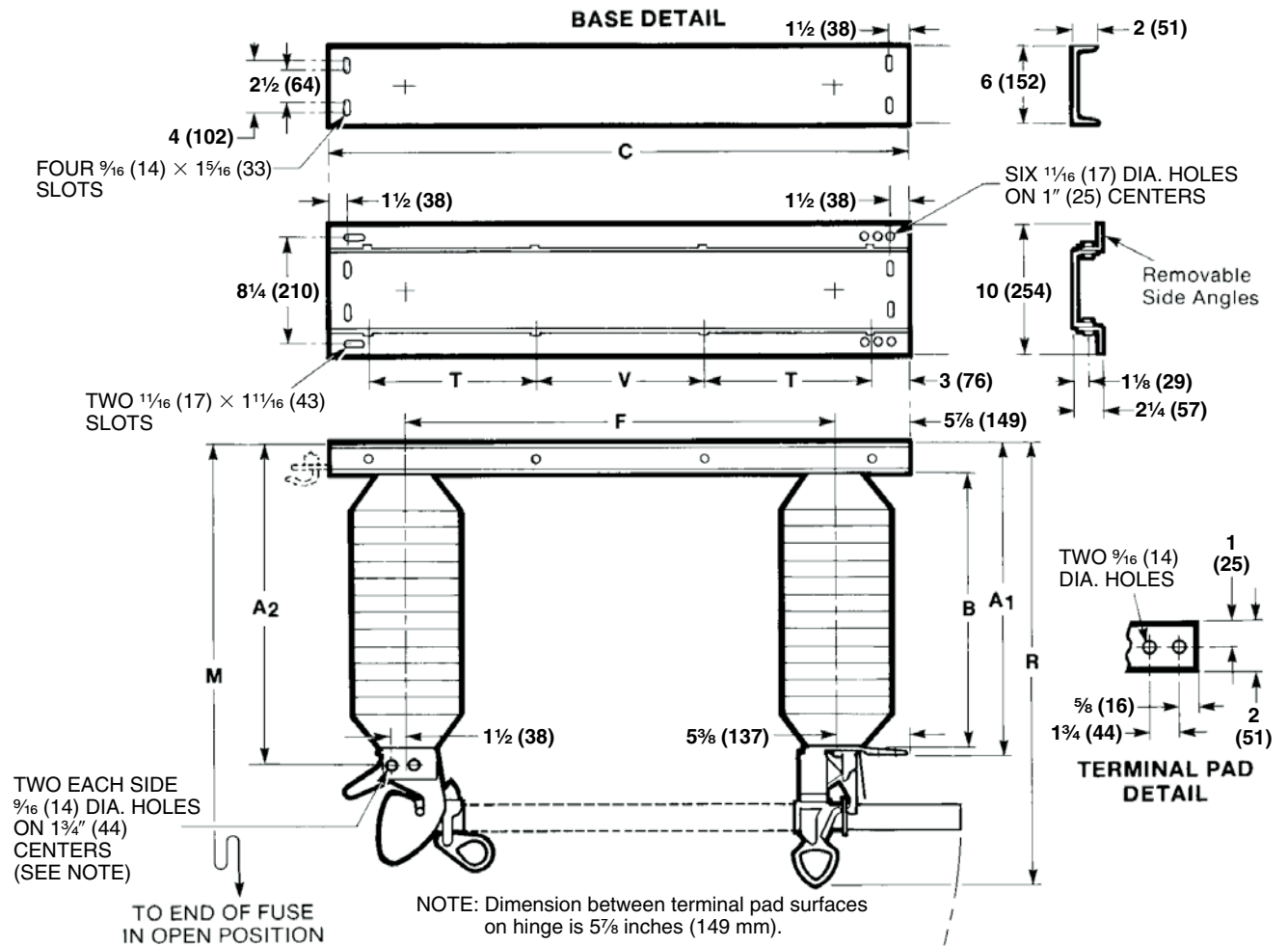

For Fuse Unit	Rating				Catalog Number Complete Mounting (including Live Parts)	Dimensions in Inches (mm)								Net Wt., Lbs. (Kg.) ^①	
	kV			Amps. Max		A ₁ ●	A ₂ ●	B	C	F	M●	R●	T		V
	Nom.	Max	BIL												
SMD-1A	34.5	38	200	200E	186714R1, 186714R1-P, 186714R1-E	20 3/4 (527)	21 1/2 (546)	18 (457)	41 (1041)	29 1/4 (743)	62 1/4 (1581)	31 1/8 (791)	17 1/2 (445)	— (—)	150 (68)
	46	48.3	250	200E	186715R1, 186715R1-P, 186715R1-E	24 3/4 (629)	25 1/2 (648)	22 (559)	45 (1143)	33 1/4 (845)	70 1/4 (1784)	35 1/8 (892)	13 (330)	13 (330)	205 (93)
	69	72.5	350	200E	186716R1, 186716R1-P	32 3/4 (832)	33 1/2 (851)	30 (762)	53 (1346)	41 1/4 (1048)	86 1/4 (2191)	43 1/8 (1095)	15 (381)	17 (432)	320 (145)
SMD-2C	34.5	38	200	300E	186944R1, 186944R1-P	20 3/4 (527)	21 7/8 (556)	18 (457)	41 (1041)	29 1/4 (743)	63 1/2 (1613)	31 1/8 (791)	17 1/2 (445)	— (—)	150 (68)
	46	48.3	250	300E	186945R1, 186945R1-P, 186945R1-E	24 3/4 (629)	25 7/8 (657)	22 (559)	45 (1143)	33 1/4 (845)	71 1/2 (1816)	35 1/8 (892)	13 (330)	13 (330)	205 (93)
SMD-2B	69	72.5	350	300E	186946R1, 186946R1-P	32 3/4 (832)	33 7/8 (860)	30 (762)	53 (1346)	41 1/4 (1048)	87 1/2 (2223)	43 1/8 (1095)	15 (381)	17 (432)	320 (145)
SMD-3	69	72.5	350	300E	192326, 192326-P	32 3/4 (832)	33 1/2 (851)	30 (762)	53 (1346)	41 1/4 (1048)	94 1/4 (2394)	43 1/8 (1095)	15 (381)	17 (432)	320 (145)

① Weights shown apply to mountings furnished with porcelain insulators. Mountings furnished with polymer or Cypoxy insulators weigh less.

● These dimensions decrease 1/4 inch (6 mm) when side angles are removed from base.

Inverted, 90° Opening Style
SMD-2B
 115 and 138 kV

Dimensions in inches (mm)

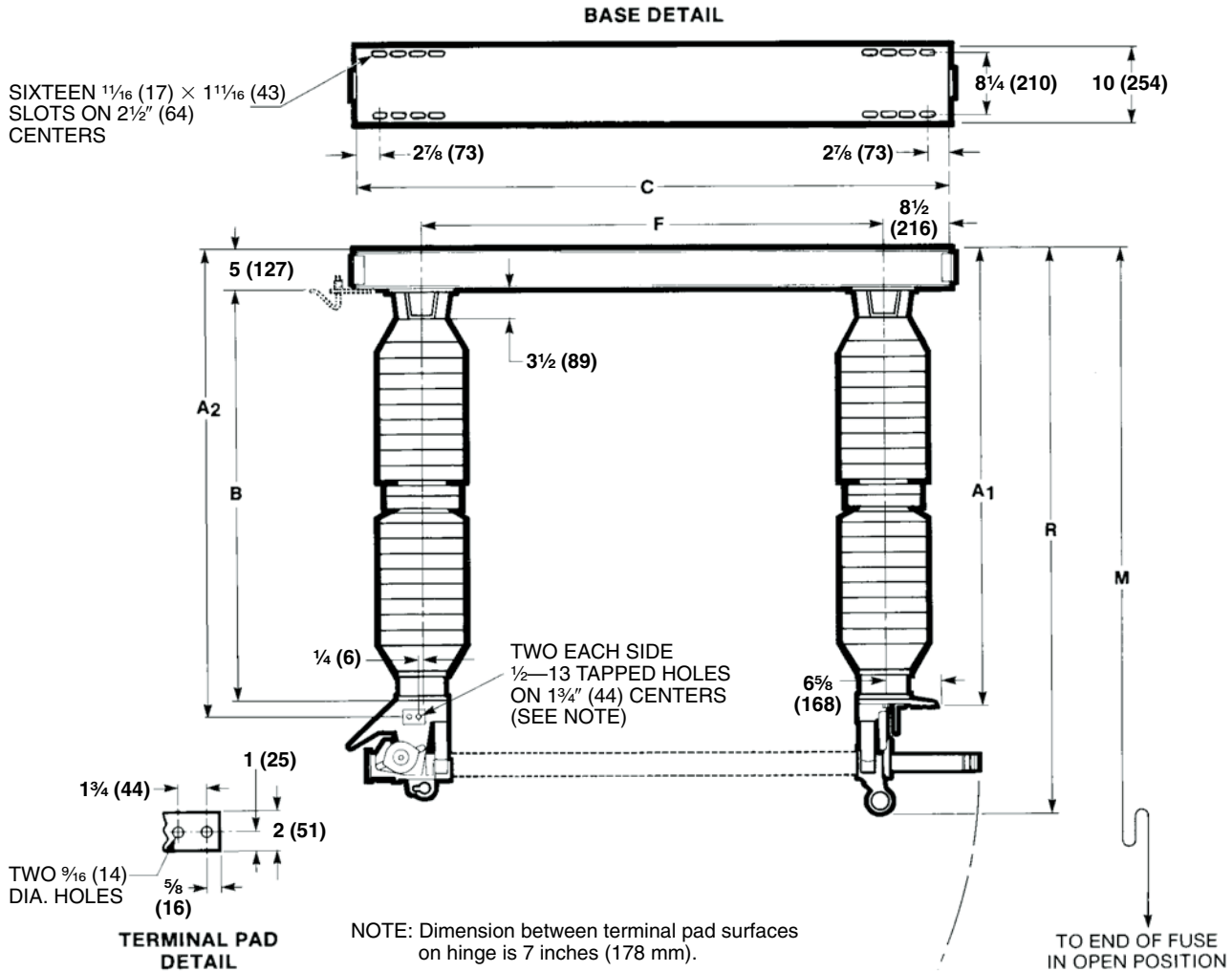

Rating				Catalog Number Complete Mounting (including Live Parts)	Dimensions in Inches (mm)							Net Wt., Lbs. (Kg.) ①
kV			Amps, Max		A ₁	A ₂	B	C	F	M	R	
Nom.	Max	BIL										
115	121	550	250E	186448R3, 186448R3-P	54 (1372)	55 $\frac{5}{8}$ (1413)	48 $\frac{1}{2}$ (1232)	76 $\frac{3}{4}$ (1949)	59 $\frac{3}{4}$ (1518)	135 $\frac{3}{4}$ (3448)	68 $\frac{5}{8}$ (1737)	600 (272)
138	145	650	250E	186849R3, 186849R3-P	63 (1600)	64 $\frac{5}{8}$ (1641)	57 $\frac{1}{2}$ (1461)	84 $\frac{3}{4}$ (2153)	67 $\frac{3}{4}$ (1721)	152 $\frac{3}{4}$ (3880)	77 $\frac{5}{8}$ (1965)	655 (297)
138	145	750	250E	186449R3, 186449R3-P	71 (1803)	72 $\frac{5}{8}$ (1845)	65 $\frac{1}{2}$ (1664)	84 $\frac{3}{4}$ (2153)	67 $\frac{3}{4}$ (1721)	160 $\frac{3}{4}$ (4083)	85 $\frac{5}{8}$ (2169)	715 (324)

① Weights shown apply to mountings furnished with porcelain insulators. Mountings furnished with polymer or Cyproxy insulators weigh less.

**Inverted, 135° Opening Style
SMD-2B and SMD-2C
115 and 138 kV**

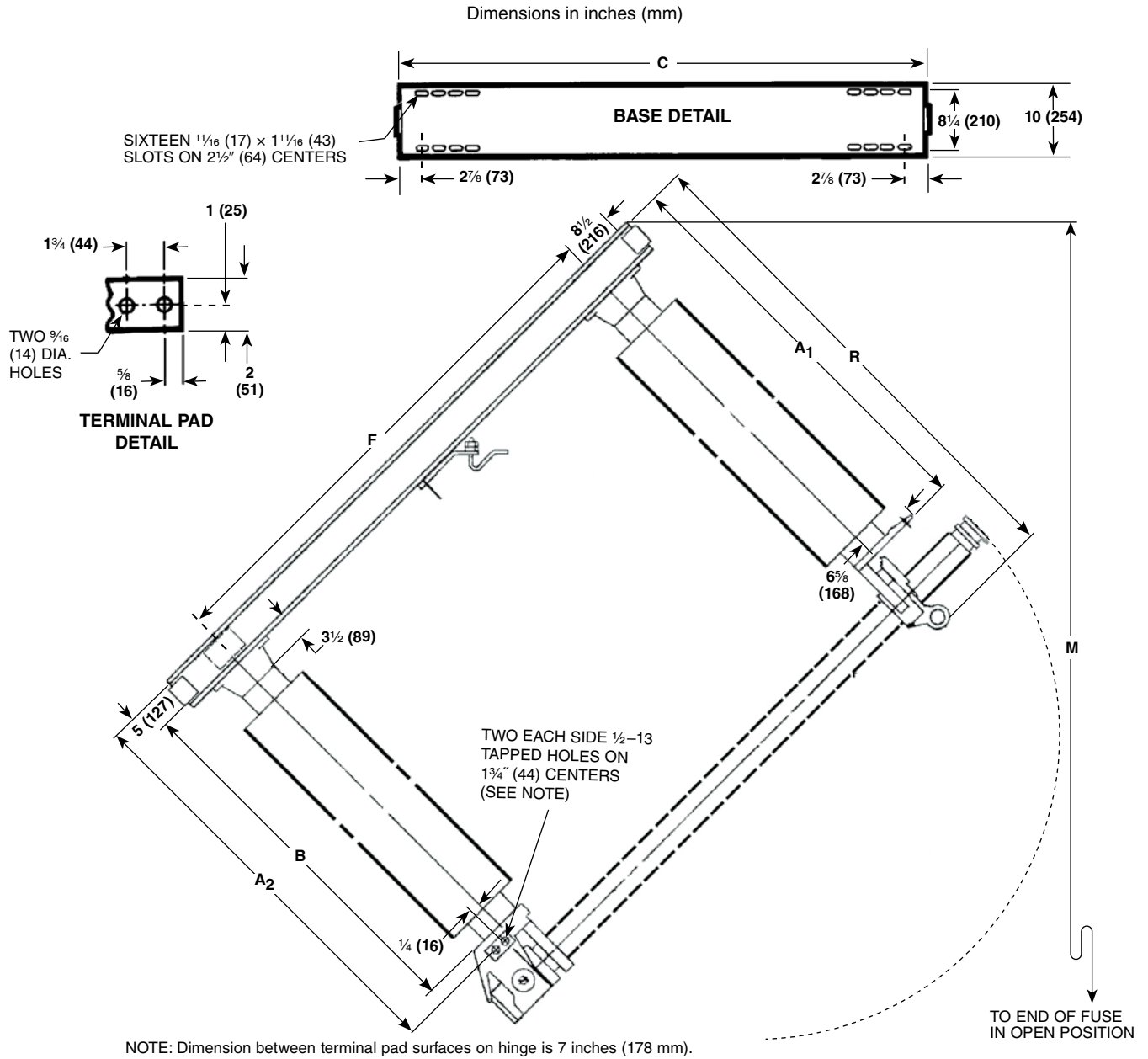

Rating				Catalog Number Complete Mounting (including Live Parts)	Dimensions in Inches (mm)							Net Wt., Lbs. (Kg.) ①
kV			Amps, Max		A ₁	A ₂	B	C	F	M	R	
Nom.	Max	BIL										
115	121	550	250E	186468, 186468-P	54 (1372)	55 $\frac{5}{8}$ (1413)	48 $\frac{1}{2}$ (1232)	76 $\frac{3}{4}$ (1949)	59 $\frac{3}{4}$ (1518)	165 (4191)	68 $\frac{5}{8}$ (1737)	600 (272)
138	145	650	250E	186869, 186869-P	63 (1600)	64 $\frac{5}{8}$ (1641)	57 $\frac{1}{2}$ (1461)	84 $\frac{3}{4}$ (2153)	67 $\frac{3}{4}$ (1721)	185 (4699)	77 $\frac{5}{8}$ (1965)	655 (297)
138	145	750	250E	186469, 186469-P	71 (1803)	72 $\frac{5}{8}$ (1845)	65 $\frac{1}{2}$ (1664)	84 $\frac{3}{4}$ (2153)	67 $\frac{3}{4}$ (1721)	193 (4902)	85 $\frac{5}{8}$ (2169)	715 (324)

① Weights shown apply to mountings furnished with porcelain insulators. Mountings furnished with polymer or Cyproxy insulators weigh less.

**Vertical-Offset Style
SMD-50
34.5, 46, and 69 kV**

Dimensions in inches (mm)

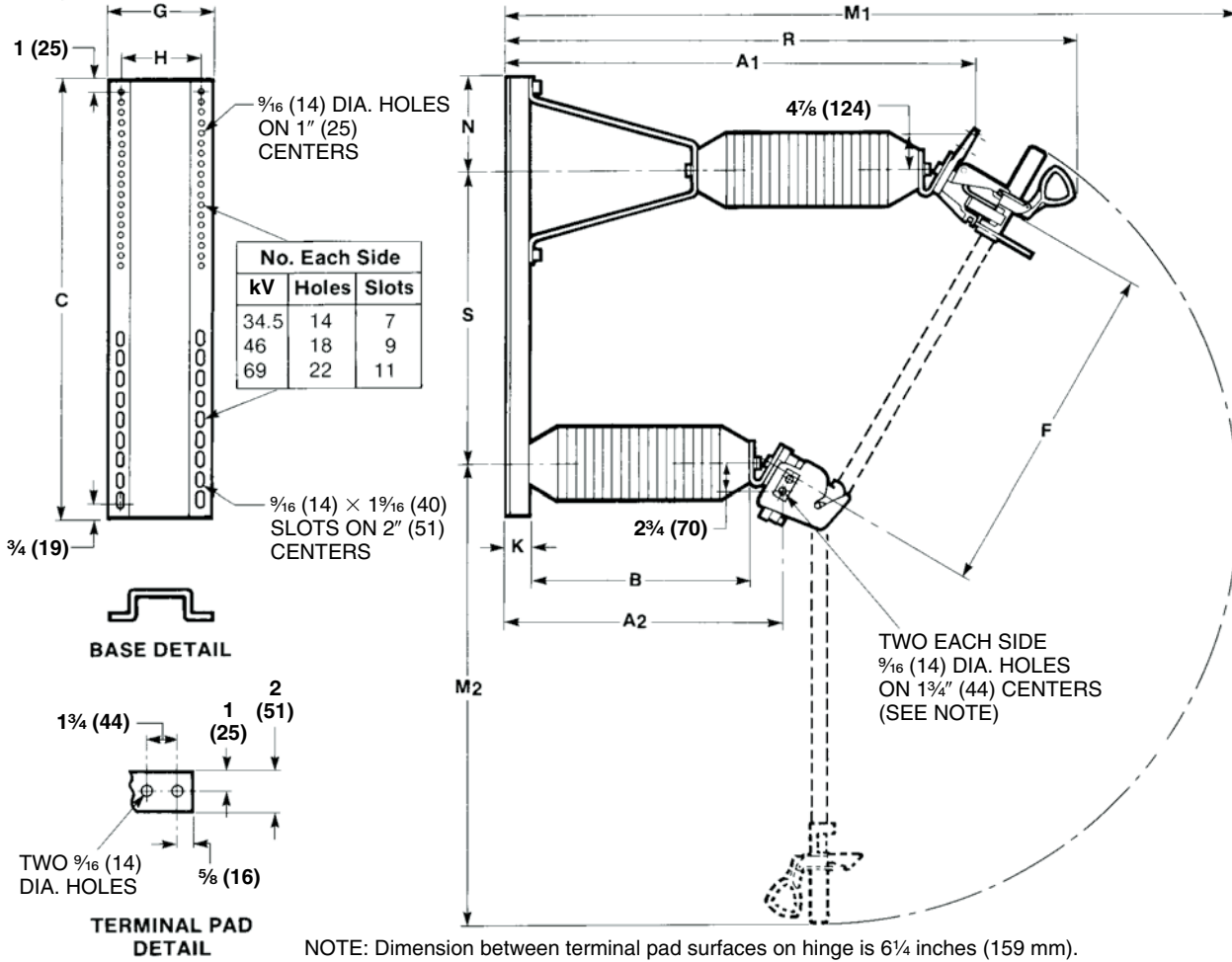

Rating				Catalog Number Complete Mounting (including Live Parts)	Dimensions in Inches (mm)											Net Wt., Lbs. (Kg.) ①		
kV			Amps, Max		A ₁	A ₂	B	C	F	G	H	K	M ₁	M ₂	N		R	S
Nom.	Max	BIL																
34.5	38	200	100E	92044R3, 92044R3-P, 92044R3-E	40 1/8 (1022)	23 3/8 (594)	18 (457)	35 1/2 (902)	29 1/4 (743)	8 7/8 (225)	7 (178)	2 (51)	63 7/8 (1622)	40 3/4 (1035)	7 (178)	49 1/8 (1248)	25 3/8 (645)	145 (66)
46	48.3	250	100E	92045R3, 92045R3-P, 92045R3-E	46 3/8 (1178)	27 5/8 (702)	22 (559)	43 (1092)	33 1/4 (845)	10 (254)	8 1/4 (210)	2 1/4 (57)	72 1/8 (1832)	44 3/4 (1137)	9 3/8 (238)	55 3/8 (1407)	28 7/8 (733)	190 (86)
69	72.5	350	100E	92046R3, 92046R3-P	58 1/2 (1486)	35 3/8 (905)	30 (762)	52 (1321)	41 1/4 (1048)	10 (254)	8 1/4 (210)	2 1/4 (57)	88 1/8 (2238)	52 3/4 (1340)	10 3/4 (273)	67 1/2 (1715)	35 7/8 (911)	270 (122)

① Weights shown apply to mountings furnished with porcelain insulators. Mountings furnished with polymer or Cytopoxy insulators weigh less.

**Vertical-Offset Style
SMD-1A, SMD-2B, and SMD-2C
34.5, 46, and 69 kV**

Dimensions in inches (mm)

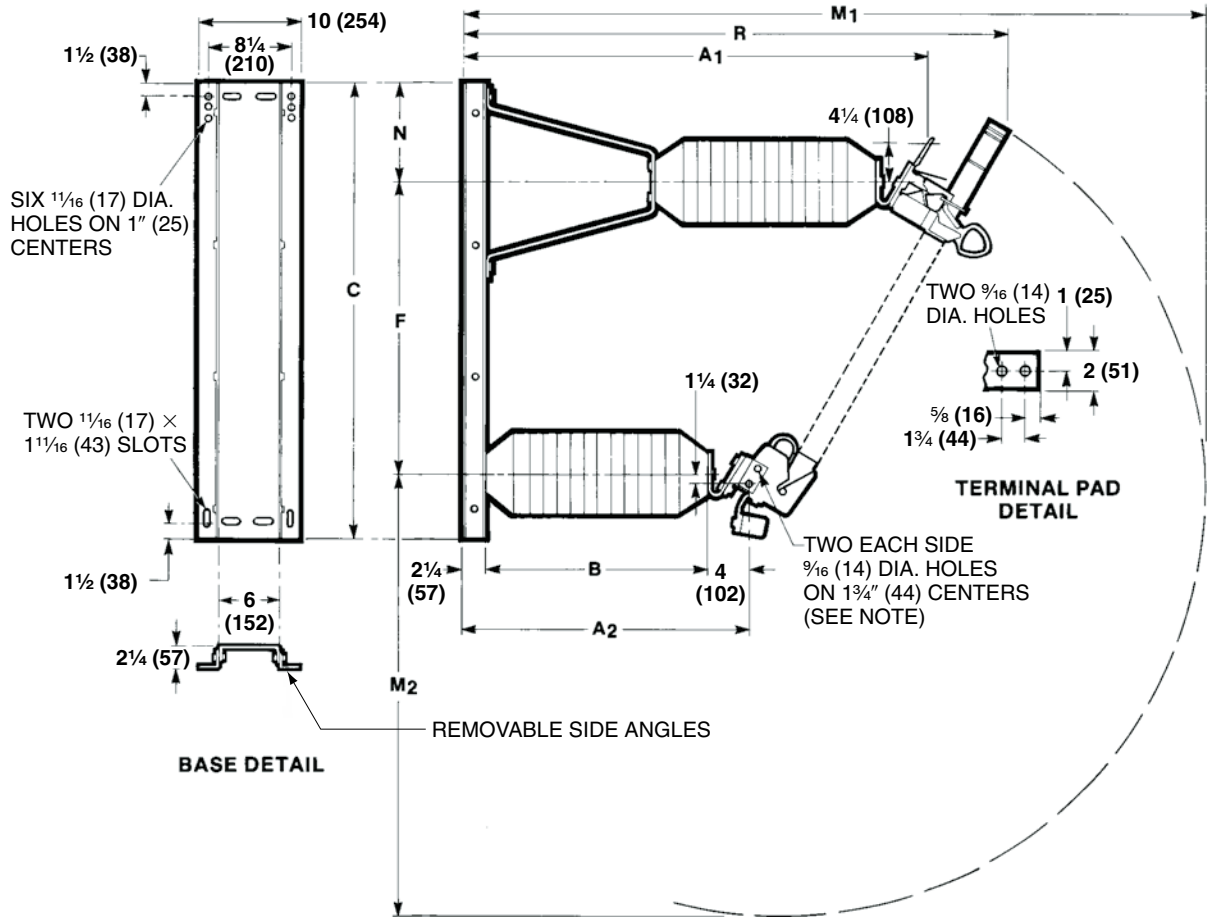

NOTE: Dimension between terminal pad surfaces on hinge is 4 3/4 inches (121 mm).

For Fuse Unit	Rating				Catalog Number Complete Mounting (including Live Parts)	Dimensions in Inches (mm)									Net Wt., Lbs. (Kg.) ①
	kV			Amps, Max		A ₁ ●	A ₂ ●	B	C	F	M ₁ ●	M ₂	N	R●	
	Nom.	Max	BIL												
SMD-1A	34.5	38	200	200E	192054, 192054-P, 192054-E	40 1/2 (1029)	24 1/4 (616)	18 (457)	41 (1041)	25 3/8 (645)	64 3/8 (1641)	38 3/4 (984)	9 3/4 (248)	47 1/2 (1207)	175 (79)
	46	48.3	250	200E	192055, 192055-P, 192055-E	46 1/2 (1181)	28 1/4 (718)	22 (559)	45 (1143)	28 7/8 (733)	72 5/8 (1845)	42 3/4 (1086)	9 7/8 (251)	53 1/2 (1359)	235 (107)
	69	72.5	350	200E	192056, 192056-P	58 3/8 (1489)	36 1/4 (921)	30 (762)	53 (1346)	35 7/8 (911)	88 5/8 (2251)	50 3/4 (1289)	11 1/4 (286)	65 1/2 (1664)	355 (161)
SMD-2C	34.5	38	200	300E	192064, 192064-P	40 1/2 (1029)	24 1/4 (616)	18 (457)	41 (1041)	25 3/8 (645)	65 7/8 (1673)	40 (1016)	9 3/4 (248)	48 1/4 (1226)	175 (79)
	46	48.3	250	300E	192065, 192065-P, 192065-E	46 1/2 (1181)	28 1/4 (718)	22 (559)	45 (1143)	28 7/8 (733)	73 7/8 (1876)	44 (1118)	9 7/8 (251)	54 1/4 (1378)	235 (107)
SMD-2B	69	72.5	350	300E	192066, 192066-P	58 3/8 (1489)	36 1/4 (921)	30 (762)	53 (1346)	35 7/8 (911)	89 7/8 (2283)	52 (1321)	11 1/4 (286)	66 1/4 (1683)	355 (161)

① Weights shown apply to mountings furnished with porcelain insulators. Mountings furnished with polymer or Cypoxy insulators weigh less.

● These dimensions decrease 1/4 inch (6 mm) when side angles are removed from base.

**Right-Angle Style
SMD-50
34.5, 46, and 69 kV**

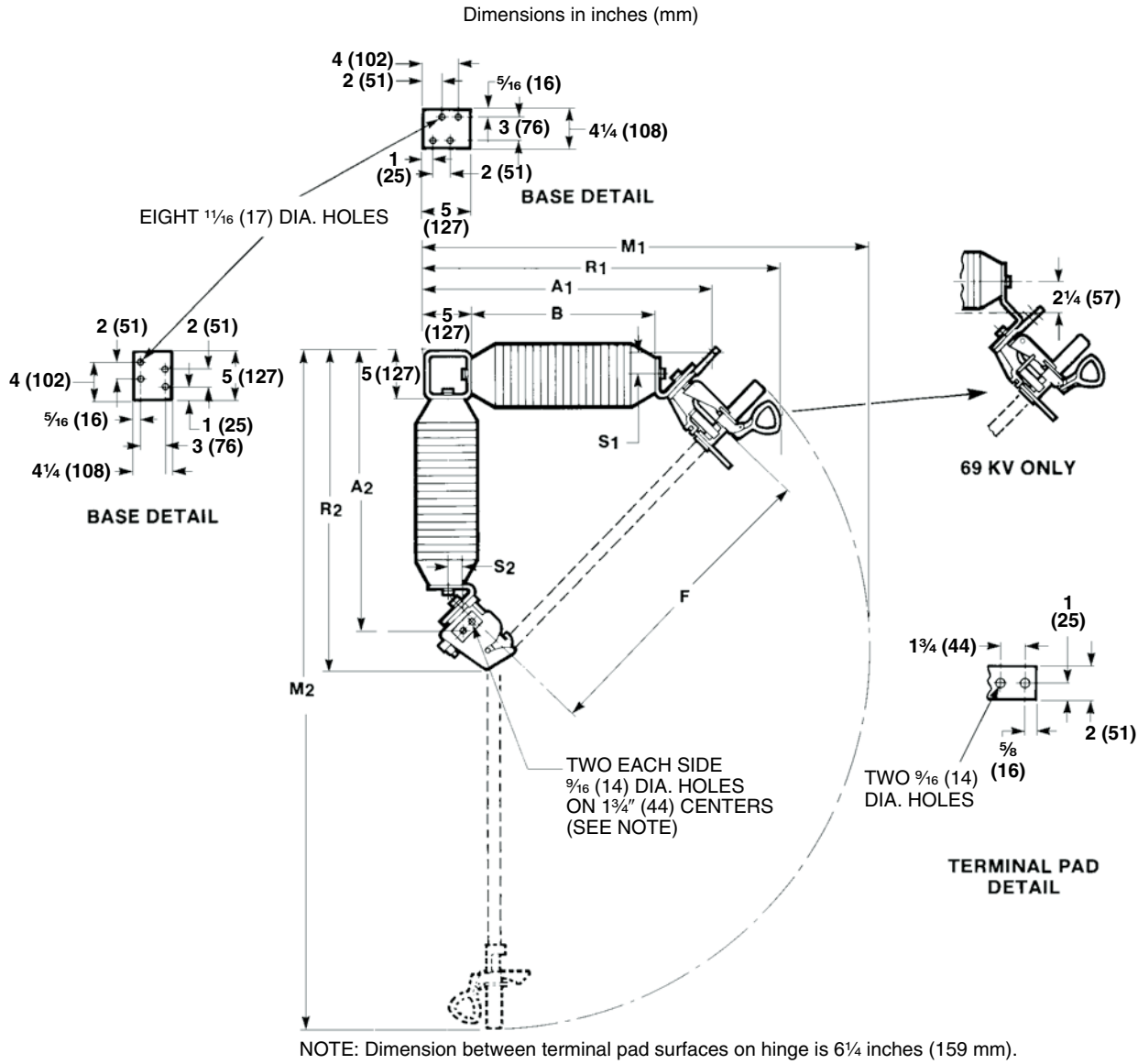

Rating				Catalog Number Complete Mounting (including Live Parts)	Dimensions in Inches (mm)								Net Wt., Lbs. (Kg.) ①		
kV			Amps, Max		A ₁	A ₂	B	F	M ₁	M ₂	R ₁	R ₂		S ₁	S ₂
Nom.	Max	BIL													
34.5	38	200	100E	92024R3, 92024R3-P, 92024R3-E	29 ⁷ / ₈ (759)	28 ³ / ₄ (730)	18 (457)	29 ¹ / ₄ (743)	45 ¹ / ₈ (1146)	67 ⁷ / ₈ (1711)	36 ⁷ / ₈ (937)	32 ³ / ₄ (832)	1 ¹ / ₂ (32)	2 ³ / ₄ (70)	105 (48)
46	48.3	250	100E	92025R3, 92025R3-P, 92025R3-E	33 ⁷ / ₈ (860)	32 ³ / ₄ (831)	22 (559)	33 ¹ / ₄ (845)	50 ¹ / ₂ (1283)	75 ⁷ / ₈ (1915)	40 ⁷ / ₈ (1038)	34 ¹ / ₄ (870)	4 (102)	4 (102)	130 (59)
69	72.5	350	100E	92026R3, 92026R3-P	39 ¹ / ₂ (1003)	40 ³ / ₄ (1035)	30 (762)	41 ¹ / ₄ (1048)	58 ¹ / ₂ (1486)	91 ³ / ₈ (2321)	46 ⁵ / ₈ (1184)	42 ¹ / ₄ (1073)	6 ¹ / ₄ (159)	4 (102)	210 (95)

① Weights shown apply to mountings furnished with porcelain insulators. Mountings furnished with polymer or Cypoxy insulators weigh less.

**Right-Angle Style
SMD-1A, SMD-2B, SMD-2C, and SMD-3
34.5, 46, and 69 kV**

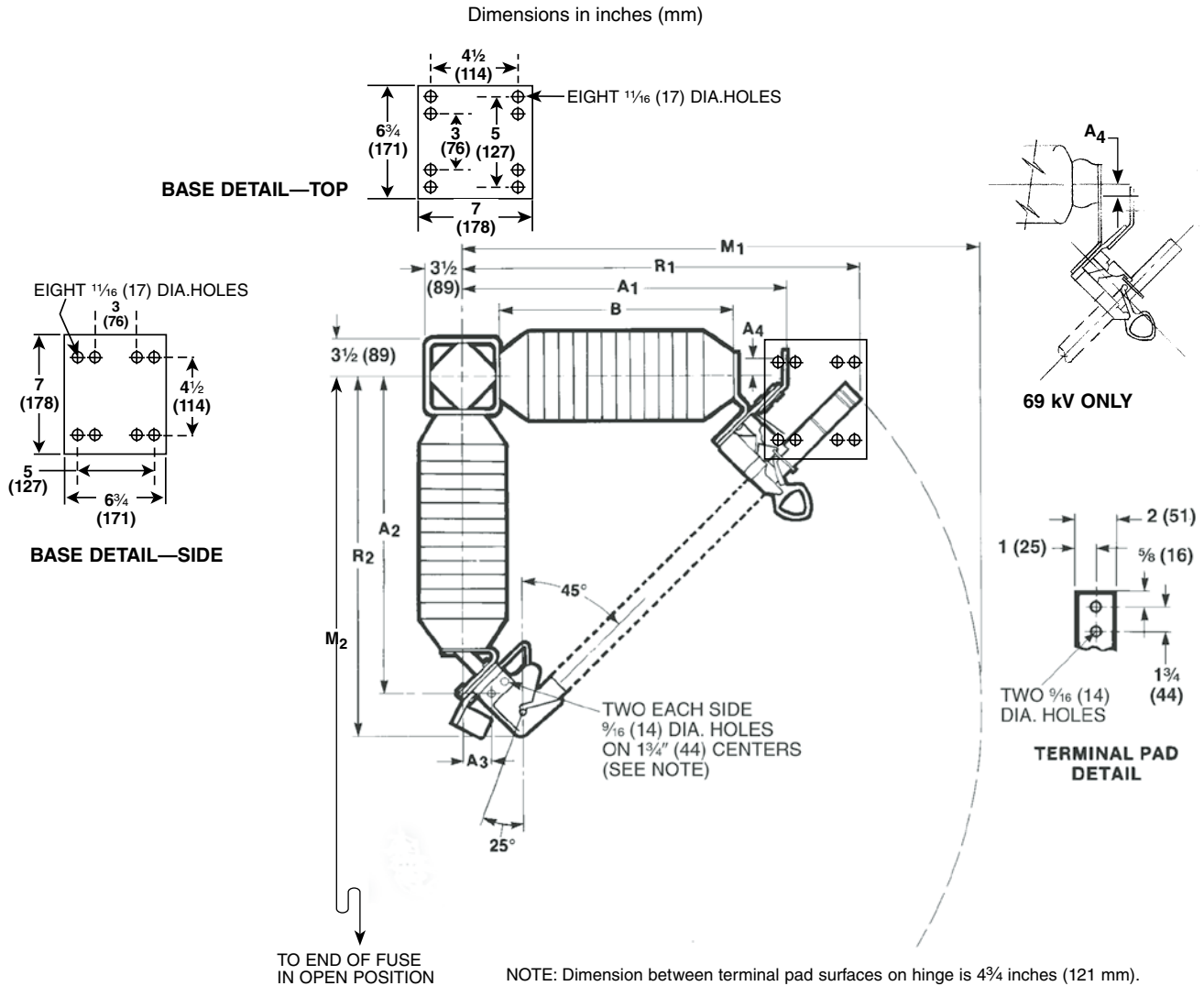

For Fuse Unit	Rating				Catalog Number Complete Mounting (including Live Parts)	Dimensions in Inches (mm)									Net Wt., Lbs. (Kg.)
	kV			Amps, Max		A ₁	A ₂	A ₃	A ₄	B	M ₁	M ₂	R ₁	R ₂	
	Nom.	Max	BIL												
SMD-1A	34.5	38	200	200E	192004R2, 192004R2-P, 192004R2-E	28 3/4 (730)	25 5/8 (645)	4 7/8 (124)	2 1/2 (64)	18 (457)	44 3/4 (1137)	64 1/8 (1629)	35 (889)	29 1/4 (743)	130 (59)
	46	48.3	250	200E	192005R2, 192005R2-P, 192005R2-E	30 (762)	29 1/2 (749)	3 1/4 (83)	1 1/8 (29)	22 (559)	47 1/8 (1197)	72 1/4 (1835)	36 1/4 (921)	33 1/2 (851)	160 (73)
	69	72.5	350	200E	192006R2, 192006R2-P	37 3/8 (949)	37 3/8 (949)	4 7/8 (124)	1 1/4 (32)	30 (762)	56 3/4 (1441)	88 1/8 (2238)	43 1/2 (1105)	41 1/4 (1048)	230 (104)
SMD-2C	34.5	38	200	300E	186864R2, 186864R2-P	28 3/4 (730)	25 5/8 (645)	4 7/8 (124)	2 1/2 (64)	18 (457)	46 (1168)	65 3/8 (1661)	36 (914)	29 1/4 (743)	130 (59)
	46	48.3	250	300E	186865R2, 186865R2-P, 186865R2-E	30 (762)	29 1/2 (749)	3 1/4 (83)	1 1/8 (29)	22 (559)	48 3/8 (1229)	73 1/2 (1867)	37 1/4 (946)	33 1/2 (851)	160 (73)
SMD-2B	69	72.5	350	300E	186866R2, 186866R2-P	37 3/8 (949)	37 3/8 (949)	4 7/8 (124)	1 1/4 (32)	30 (762)	58 (1473)	89 3/8 (2270)	44 1/2 (1130)	41 1/4 (1048)	230 (104)
SMD-3	69	72.5	350	300E	192346, 192346-P	37 3/8 (949)	37 3/4 (959)	4 1/2 (114)	1 1/4 (32)	30 (762)	64 1/2 (1638)	96 3/8 (2454)	48 7/8 (1241)	41 1/4 (1048)	230 (104)

